

MAC TW1

user manual



Dimensions

All dimensions are in millimeters

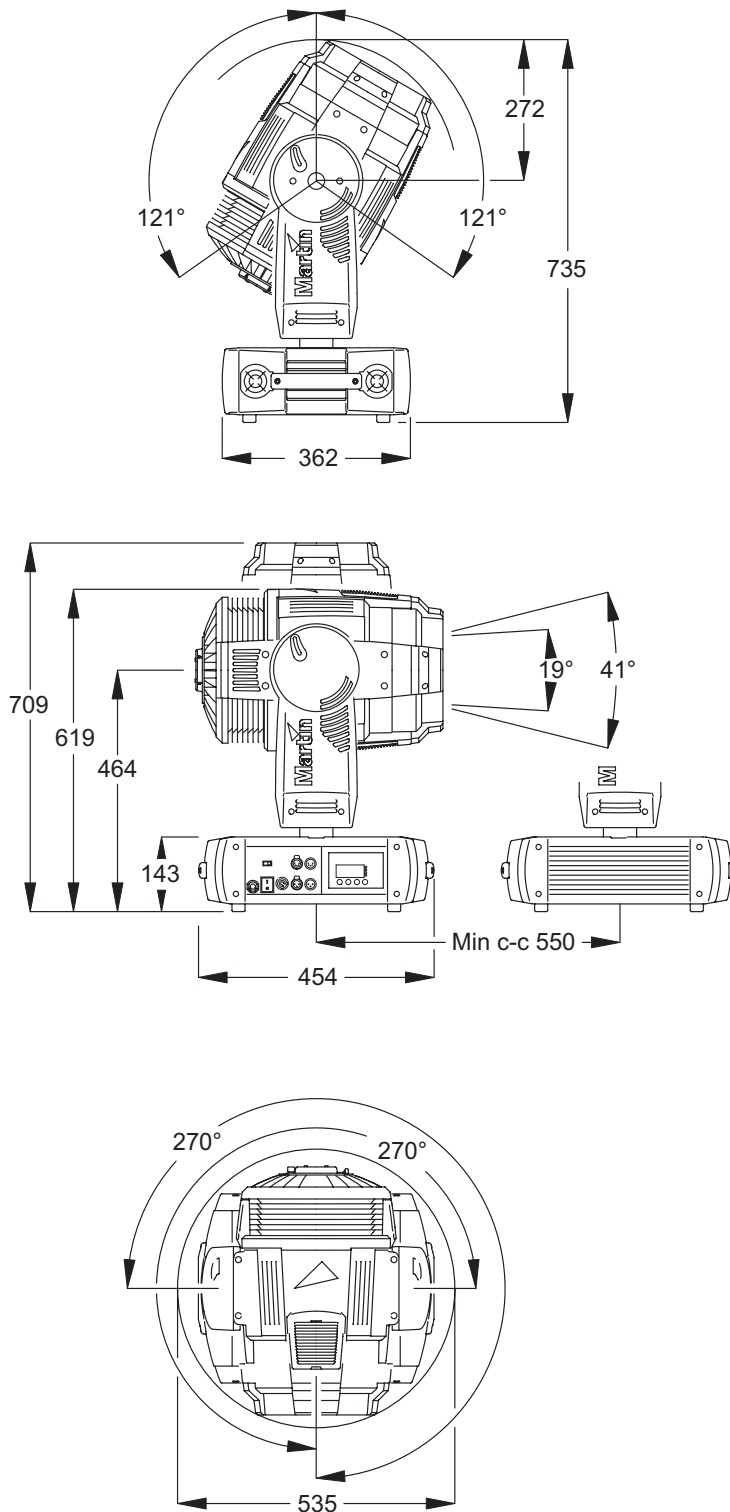

©2006 Martin Professional A/S, Denmark. All rights reserved. No part of this manual may be reproduced, in any form or by any means, without permission in writing from Martin Professional A/S. Information subject to change without notice. Martin Professional A/S and all affiliated companies disclaim liability for any injury, damage, direct or indirect loss, consequential or economic loss or any other loss occasioned by the use of, inability to use or reliance on the information contained in this manual.

Safety Information



WARNING!

Read the safety precautions in this section before installing, powering, operating or servicing this product.

The following symbols are used to identify important safety information on the product and in this manual:



DANGER!
Safety hazard.
Risk of severe injury or death.



DANGER!
Refer to manual before installing, powering or servicing.



DANGER!
Hazardous voltage. Risk of lethal or severe electric shock.



Warning!
Fire hazard.



Warning!
Burn hazard.
Hot surface. Do not touch.



Warning!
Risk of eye injury. Safety glasses must be worn.



Warning!
Risk of hand injury. Safety gloves must be worn.



This product is for professional use only. It is not for household use.

This product presents risks of severe injury or death due to fire and burn hazards, electric shock, lamp explosion and falls.



Read this manual before installing, powering or servicing the fixture, follow the safety precautions listed below and observe all warnings in this manual and printed on the fixture. If you have questions about how to operate the fixture safely, please contact your Martin dealer or call the Martin 24-hour service hotline at +45 70 200 201.



PROTECTION FROM ELECTRIC SHOCK

- Disconnect the fixture from AC power before removing or installing any cover or part – including the lamp and fuses – and when not in use.
- Always ground (earth) the fixture electrically.
- Use only a source of AC power that complies with local building and electrical codes and has both overload and ground-fault (earth-fault) protection.
- Connect this fixture to AC power either using the supplied power cable or via 3-conductor cable that is rated minimum 20 amp, extra hard usage. Suitable cable types include ST, STW, SEO, SEOW and STO.
- Before using the fixture, check that all power distribution equipment and cables are in perfect condition and rated for the current requirements of all connected devices.
- Do not use the fixture if the power cable or power plug are in any way damaged, defective or wet, or if they show signs of overheating.
- Do not expose the fixture to rain or moisture.
- Refer any service operation not described in this manual to a qualified technician.



PROTECTION FROM EYE INJURY

- Do not operate the fixture with missing or damaged covers, shields, lenses or screens.
- Allow the fixture to cool for at least 45 minutes before opening it or removing the lamp.
- Protect hands and eyes with safety gloves and safety glasses when handling lamps.
- Do not stare directly into the light. Never look at an exposed lamp while it is lit.



PROTECTION FROM BURNS AND FIRE

- The exterior of the fixture becomes very hot – up to 200° C (392° F) – during use. Avoid contact by persons and materials. Allow the fixture to cool for at least 45 minutes before handling.
- Never attempt to bypass the thermostatic switch or fuses. Always replace defective fuses with ones of the specified type and rating.
- Keep all combustible materials (e.g. fabric, wood, paper) at least 0.5 m (20 in.) away from the fixture. Keep flammable materials well away from the fixture.
- Do not illuminate surfaces within 0.5 m (20 in.) of the fixture.
- Provide a minimum clearance of 0.1 m (4 in.) around fans and air vents.
- Never stick filters, masks or other materials onto any lens or other optical component.
- Do not modify the fixture or install other than genuine Martin parts.
- Do not operate the fixture if the ambient temperature (Ta) exceeds 40° C (104° F).
- Replace the lamp immediately if it becomes visually deformed, damaged or in any way defective
- Monitor hours of lamp use and average lamp intensity and replace the lamp when you estimate that the lamp has reached the limit of its service life.



PROTECTION FROM INJURY DUE TO FALLS

- Do not lift or carry the fixture alone.
- Use two evenly spaced clamps to suspend the fixture from rigging structures. Do not use only one clamp.
- When suspending the fixture, ensure that the structure and all hardware used can hold at least 10 times the weight of all devices suspended from them.
- Use a secondary attachment such as a safety cable that is approved for the weight of the fixture and installed as described in this manual.
- Check that all external covers and rigging hardware are securely fastened.
- Block access below the work area and work from a stable platform whenever installing, servicing or moving the fixture.



Disposing of this product

Martin products are supplied in compliance with Directive 2002/96/EC of the European Parliament and of the Council of the European Union on WEEE (Waste Electrical and Electronic Equipment), as amended by Directive 2003/108/EC, where applicable.

Help preserve the environment! Ensure that this product is recycled at the end of its life. Your supplier can give details of local arrangements for the disposal of Martin products.

Contents

Dimensions	2
Safety Information.....	3
Introduction	7
Unpacking	7
Using for the first time	7
Connections and control panel	8
AC power	9
Power voltage and main fuses.....	9
Power connection	9
Lamp	10
About the halogen lamp.....	10
Lamp replacement.....	10
Dimming	12
Dimming options and lamp voltage	12
Connecting an external dimmer system	13
DMX data link.....	14
Tips for reliable data transmission.....	14
Connecting the data link	14
Rigging	15
Setup.....	16
Control panel	16
Menu navigation	16
DMX address and protocol	16
Tailoring performance	17
Readouts	18
Manual control	19
Service utilities.....	19
LED indicators	20
Operation	21
Fixture reset.....	21
Electronic dimming	21
Mechanical dimming	21
Cyan, Magenta and Yellow	21
Zoom	21
Pan and tilt.....	22
Pan/tilt speed and effects speed channels	22
Control menu settings	22
Service and maintenance.....	23
Tilt lock.....	23
Optical path	23
Accessing and removing effects components.....	24
Cleaning.....	24
Lubrication	26
Fuse replacement	26
Software installation.....	26
MAC TW1 DMX protocol	28
Control menu	30
Control panel shortcuts	32
Adjustment submenu	33
Display messages.....	34
Troubleshooting	35
Circuit board connections.....	36
MAC TW1 specifications.....	37

Notes

Introduction

Thank you for selecting the MAC TW1, an intelligent lighting fixture from Martin. This moving-head washlight features:

- 1200 watt high-output tungsten halogen lamp
- CMY color mixing with 0-100% continuously variable independent CMY control
- Motorized zoom: 19° - 41° one-tenth peak angle (lamp type affects precise angle limits)
- 540° of pan and 242° of tilt
- DMX control with fine (16-bit) control of electronic and mechanical dimmers, cyan, magenta, yellow, pan, tilt and zoom
- Mechanical dimmer/shutter with instant intensity control, 2 - 10 Hz strobe effect and full range dimming with no effect on color temperature
- Multi-voltage or 80 V internal dimmer
- External dimmer connection
- Auto-sensing switch-mode power supply
- Intelligent lamp power control when using an external dimmer
- Patent-pending ducted forced air lamp cooling system

For the latest firmware updates, documentation, and other information about this and all Martin Professional products, please visit the Martin website at <http://www.martin.com>

Comments or suggestions regarding this document may be e-mailed to service@martin.dk or posted to:

Service Department
Martin Professional A/S
Olof Palmes Allé 18
DK-8200 Aarhus N
Denmark



DANGER! Read "Safety Information" on page 3 before installing, powering, operating or servicing the MAC TW1.

Unpacking

The MAC TW1 is packaged in either a cardboard box or a two-unit flight case that is designed to protect the product during shipment. The following items are included:

- Two clamp attachment brackets
- Four 20 AT fuses (installed)
- This user manual

Using for the first time

Before applying power to the fixture:

- Carefully review "Safety Information" on page 3.
- Check that the local AC power voltage is within the ranges listed on the serial number label and in "Power voltage and main fuses" on page 9.
- Read the sections headed "Lamp" on page 10 and "Dimming options and lamp voltage" on page 12, then install a lamp of an approved type and with a correct voltage rating.
- Install a power plug on the power cable as described in "Power connection" on page 9.
- Release the tilt lock as described on page 23.

Connections and control panel

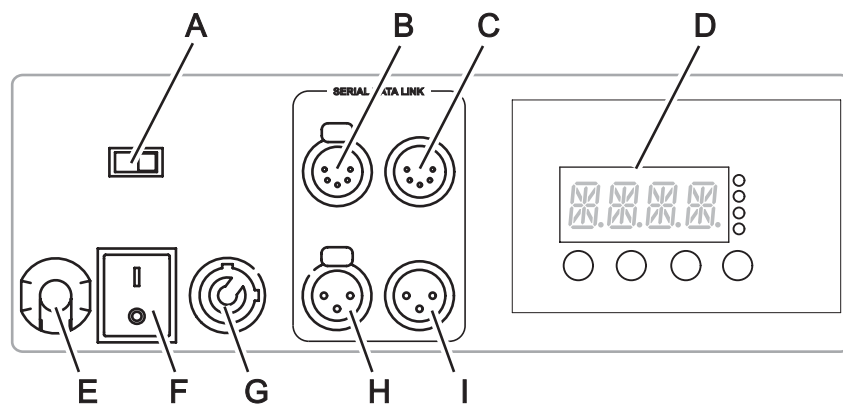

A - Internal/external lamp power switch

B - DMX out

C - DMX in

D - Control panel with LED display

E - Power cable entry

F - Power on/off switch

G - Lamp power input from external dimmer

H - DMX out

I - DMX in

AC power



DANGER! Read “Safety Information” on page 3 before connecting the MAC TW1 to AC power.

Important! Before applying power to the MAC TW1, make sure that the lamp voltage rating exactly matches the output voltage of the internal or external dimming system used, or damage can be caused that is not covered by the product warranty. See “Dimming options and lamp voltage” on page 12 for full details.

Although the lamp can be supplied with power using an external dimming system if required, the main power input of the MAC TW1 must be connected directly to AC power. Do not use an external dimming system to supply power to the fixture via the main power input, or you may obtain irregular light output and cause damage the fixture that is not covered by the product warranty.

Power voltage and main fuses



DANGER! Replace fuses with ones of the same type and rating only.

The MAC TW1 features an auto-sensing switch-mode power supply that automatically adapts to 100-120 V and 200-240 V nominal AC power at 50 or 60 Hz.



Note that power to the lamp is supplied at the output voltage from the dimmer. If using a multi-voltage IGBT internal dimmer, the output voltage from the dimmer is the same as the input voltage to the fixture and the lamp must therefore be rated at the AC power voltage the fixture is connected to. See “Dimming options and lamp voltage” on page 12 for full details. Check the lamp voltage rating before applying power. Damage caused by using an incorrectly rated lamp is not covered by the product warranty.

Power circuits are protected by two 20 amp main fuses, one on the live and one on the neutral conductor. The fuses are located on a PCB in the base. The external dimmer lamp power circuit is likewise protected by two 20 amp fuses on a PCB in the base. See “Fuse replacement” on page 26 for details of accessing and changing fuses.

Power connection



DANGER! For protection from electric shock, the fixture must be grounded (earthed). The AC mains supply must be fitted with a fuse or circuit breaker and ground-fault (earth-fault) protection. Check that the correct fuses are installed before applying power.



You may need to fit the power cable with a power plug that is suitable for your AC power outlets. If so, install a grounding-type (earthed) plug that is correctly rated for the current and power requirements of the fixture. Follow the plug manufacturer’s instructions. Table 1 shows some possible pin identification schemes; if pins are not clearly identified, or if you have any doubts about proper installation, consult a qualified electrician.

Wire Color	Pin	Symbol	Screw (US)
brown	live	L	yellow or brass
blue	neutral	N	silver
yellow/green	ground (earth)		green

Table 1: Power plug connections

To apply power, first check that the head tilt locks are released and then set the power switch on the base to the “I” position.

Lamp



DANGER! Installing a lamp that is not specified in this manual may create a safety hazard and damage the fixture. Replace the lamp immediately if it is deformed or in any way defective.

Important! The lamp voltage rating must exactly match the output voltage of the internal or external dimming system used, or serious damage can be caused that is not covered by the product warranty. See “Dimming options and lamp voltage” on page 12 for full details.

About the halogen lamp

The MAC TW1 is designed for use with the following 1200 watt tungsten-halogen lamps:

- Philips Hi-Brite 1200/80 FastFit: 80 V (P/N 97000006)
- Philips 1200/115 FastFit: 115 V (P/N 97000112)
- Philips 1200/230 FastFit: 230 V (P/N 97000113)
- Philips 1200/240 FastFit: 240 V (P/N 97000114)

This range of lamps has a color temperature of 3200 K, a color rendering index of 100, and an average service life of 300 hours at full intensity. Lamps have an integral ceramic base.

To reduce the risk of lamp failure or explosion, replace the lamp when it reaches the limit of its average service life. Note that lamp life is significantly extended while the lamp is dimmed and if the fixture is set to economy mode (see “Lamp management” on page 17). Hours of lamp use are logged and can be read in the fixture’s display (see “Readouts” on page 18).

Lamp replacement



Warning! Wear safety glasses and gloves when handling lamps. The clear lamp bulb is integral with the ceramic lamp base. Do not try to separate the bulb from the base.

Replacement lamps are available from your Martin dealer.

The clear bulb must be perfectly clean. Do not touch it with your fingers. Clean the lamp with an alcohol wipe and polish it with a dry cloth before installing, particularly if you accidentally touch the bulb.



To replace the lamp:

1. Disconnect the fixture from power and allow it to cool for at least 45 minutes.
2. Lock the head.
3. Release the screw on the lamp access cover and open the cover.

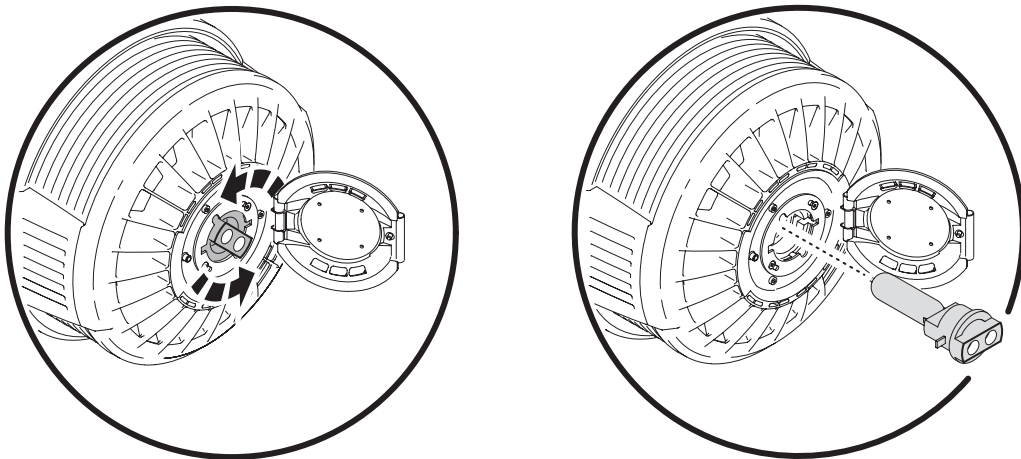

Figure 2: Lamp removal / refitting

4. Grasp the ceramic lamp base, twist it 45° counterclockwise and withdraw the lamp from the fixture as shown in Figure 2.
5. Check that the replacement lamp is correctly rated for the voltage of the dimming system output (see “Dimming options and lamp voltage” on page 12 for full details).
6. The lamp base has two metal contacts, one narrow and one wide, that fit into corresponding narrow and wide slots in the lampholder. Line up the contacts on the replacement lamp’s base with the corresponding slots in the lampholder, slide the lamp into the fixture so that the contacts are fully engaged in the slots, and then twist the lamp base 45° clockwise until it locks into position with a noticeable click.
7. Close the lamp access cover and tighten the screw to secure the cover before reapplying power.
8. After installing a new lamp, reset the lamp hour counter (see “Time” on page 18). We recommend that you label the fixture with the voltage rating of the installed lamp.

LAMP ADJUSTMENT



Warning! Adjust the lamp with the fixture cool. The fixture may become hot during adjustment, so wear heat-resistant safety gloves.

As well as being undesirable for aesthetic reasons, a significant hot-spot in the beam will focus extra heat onto optical components and may cause damage that is not covered by the product warranty.



After fitting a new lamp, adjustment may be required to obtain an even beam.

To adjust the lamp:

1. If the fixture has been in use, allow it to cool for at least 45 minutes to avoid the danger of burns, and wear heat-resistant safety gloves.
2. Apply power, allow the fixture to reset, then set zoom to narrow (DMX value 255 on channel 7 in basic or 12 in extended mode), turn on the lamp and open the mechanical shutter.
3. Aim the fixture at an even surface and make sure no further commands can be sent by DMX.
4. Release the screw on the lamp access cover and open the cover.
5. See Figure 3. Screw the three 3 mm Allen screws (arrowed) in or out to obtain the most even beam.
6. Close and secure the lamp access cover.

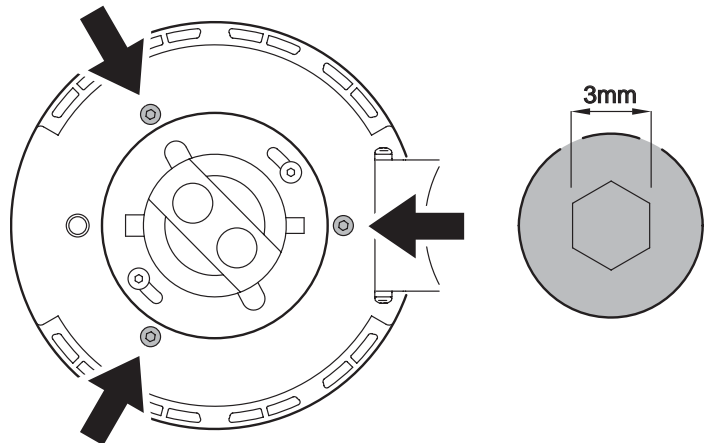

Figure 3: Lamp adjustment screws

Dimming

Dimming options and lamp voltage

Important! The lamp voltage rating must exactly match dimmer output voltage. Installing a lamp with an incorrect voltage rating may damage the dimmer beyond repair and/or destroy the lamp as soon as power is applied.

Three dimming options are available for the MAC TW1. Regardless of which option is used, the voltage rating of the lamp must match the voltage supplied by the dimming device or system (see also Figure 4):

- A model with an internal auto-sensing IGBT dimmer is available. This dimmer accepts power in the voltage ranges accepted by the fixture (100-120 V and 200-240 VAC nominal at 50/60 Hz) and supplies the lamp with power at the voltage supplied to the fixture. If the internal multi-voltage dimmer is used, the lamp voltage rating must match the voltage at the fixture's power input.
- A model with an internal 80 V dimmer is available. This dimmer is also available as an accessory but must be installed by a qualified service technician. If an 80 V internal dimmer is used, the lamp must be rated 80 V regardless of the voltage at the fixture's power input.
- Power from an external dimming device or system can be supplied directly to the lamp in all models via a Neutrik PowerCon® connector in the fixture's base. If external dimming is used, the lamp voltage rating must match the external dimmer's output voltage regardless of the voltage at the fixture's power input.

We strongly recommend that you keep a record of the lamp voltage rating and internal dimmer type installed and label these clearly on the fixture.

Do not apply power to the fixture or move the internal/external lamp power switch on the connections panel unless you are certain that the lamp voltage rating is correct for the dimming system you are using or switching to.

Damage caused by using a lamp with an incorrect voltage rating is not covered by the product warranty.

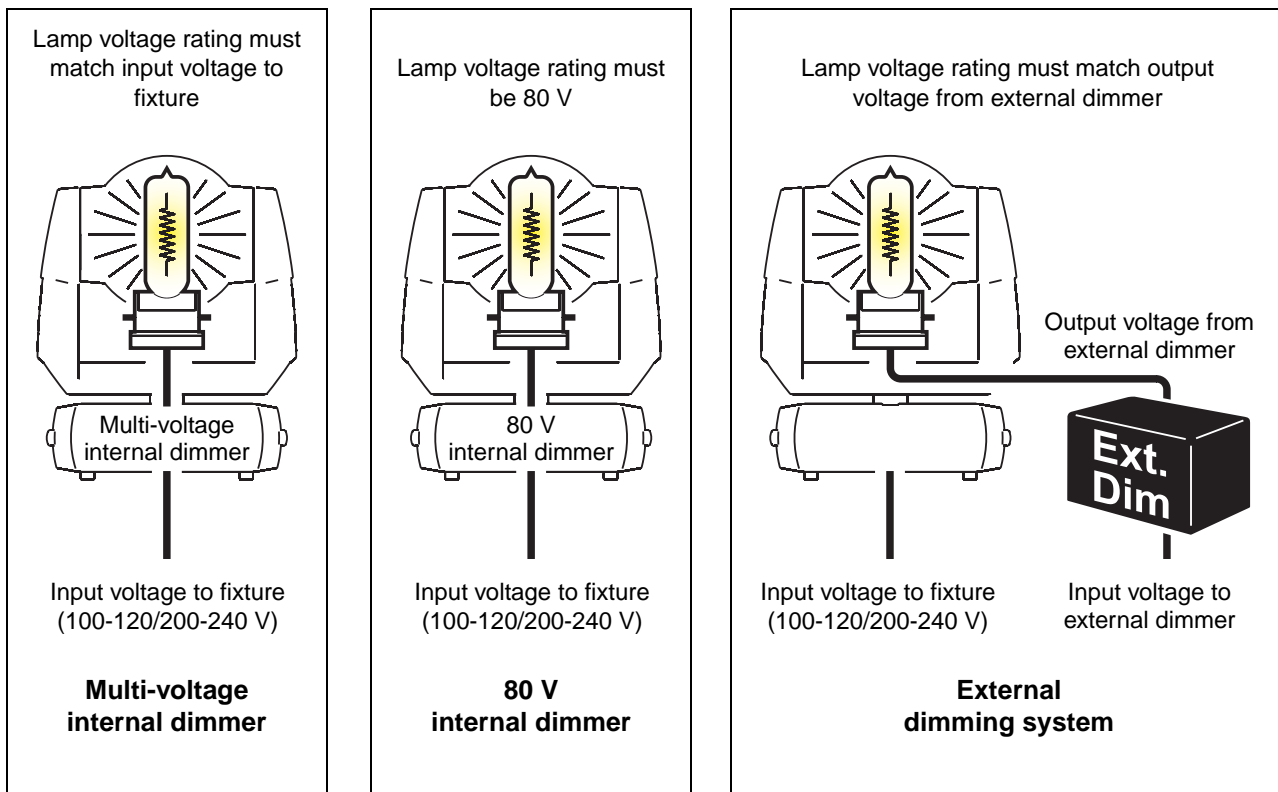

Figure 4: Dimming options and lamp voltage

Connecting an external dimmer system



DANGER! Make sure that any external dimming system used with the MAC TW1 is connected to ground (earth) and protected by overload and ground fault (earth leakage) circuit breakers. Check that the dimming system and cables are correctly rated for the power and current requirements of the lamp, and check that the lamp voltage rating matches the dimming system output voltage.



Important! Connect lamp power from an external dimming system via the Neutrik PowerCon® connector on the connections panel only.



Power can be supplied directly to the MAC TW1 lamp by an external dimming system, simplifying grouped dimming control in installations with existing fixtures and dimming circuits.

The MAC TW1 has an intelligent lamp power system that blocks power to the lamp from an external dimming system unless the fixture is powered on, has reset and is operating correctly.

The external dimming power cable must be fitted with a Neutrik PowerCon® NAC3FCA cable connector for connection to the MAC TW1. If the dimming cable does not already have this type of connector, it can be obtained from your Martin supplier (P/N 05342804). The pinout is marked on the connector. Connect the terminal marked \perp to ground (earth), the terminal marked **N** to neutral, and the terminal marked **L** to live.

CONNECTING

To connect an external dimming system:

1. Isolate the MAC TW1 and external dimming system from power.
2. Check that the external dimming system is correctly rated for the power and current requirements of the lamp, and that a lamp with the correct voltage rating for the external dimming system's output voltage is installed in the fixture.
3. Connect the external dimming power cable via the Neutrik PowerCon® connector on the MAC TW1's connections panel. To plug the cable in, line up the raised tab on the cable connector with the keyway in the chassis connector, push the cable connector in and twist clockwise to lock.
4. Move the Lamp Power switch on the connections panel to the **External** position.
5. Apply power to the MAC TW1 and allow it to reset.
6. Once the MAC TW1 has reset successfully, you can supply power to the lamp from the external dimming system.

DISCONNECTING

To disconnect an external dimming system:

1. Isolate the MAC TW1 and external dimming system from power.
2. See Figure 4. Check that a lamp with the correct voltage rating for the internal dimmer is installed in the fixture.
3. Disconnect the external dimming power cable from the PowerCon® connector on the MAC TW1's connections panel. To remove the cable connector, pull back the latch to release the lock, twist the connector counterclockwise and pull out.
4. Move the Lamp Power switch on the connections panel to the **Internal** position before applying power to the MAC TW1.

DMX data link

Important! Never connect more than 1 data input and 1 data output.

The MAC TW1 has both 3-pin and 5-pin XLR sockets for DMX data input and output. The pin-out on all sockets is pin 1 to shield, pin 2 to cold (-), and pin 3 to hot (+).

Pins 4 and 5 in the 5-pin XLR sockets are available for enhanced features in conformity with DMX 512-A. Pin-outs are pin 4 to data 2 cold (-) and pin 5 to data 2 hot (+).

Sockets are wired in parallel: both inputs connect to both outputs. *To avoid damage to the fixture, never use more than one input and one output socket.*

Tips for reliable data transmission

- Use shielded twisted-pair cable designed for RS-485 devices: standard microphone cable cannot transmit control data reliably over long runs. 24 AWG cable is suitable for runs up to 300 meters (1000 ft). Heavier gauge cable and/or an amplifier is recommended for longer runs.
- Never use both outputs to split the link. To split the serial link into branches use a splitter such as the Martin 4-Channel Opto-Isolated RS-485 Splitter/Amplifier.
- Do not overload the link. Up to 32 devices may be connected on a serial link.
- Terminate the link by installing a termination plug in the output socket of the last fixture. The termination plug, which is a male XLR plug with a 120 Ohm, 0.25 Watt resistor soldered between pins 2 and 3, "soaks up" the control signal so it does not reflect and cause interference. If a splitter is used, terminate each branch of the link.
- Some older fixtures have reversed polarity data sockets (pin 2 hot and pin 3 cold). Polarity is normally labelled on devices and described in user manuals. *Use a phase-reversing cable between the MAC TW1 and any device with reversed polarity.*

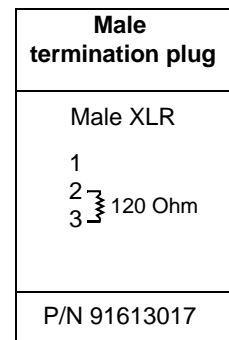
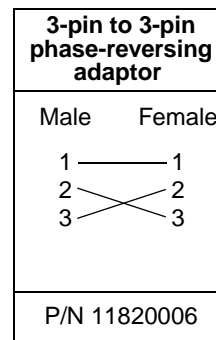

Connecting the data link

1. Connect the DMX data output from the controller to the MAC TW1's 3-pin or 5-pin input (male) socket.
2. Using the sockets that match your data cable, connect the output of the fixture closest to the controller to the input of the next fixture.
3. Insert a male 120 Ohm XLR termination plug in the 3-pin or 5-pin output of the last fixture on the link.

Rigging

The MAC TW1 can be placed on stage or clamped to a truss in any orientation. The mounting points allow the clamp brackets to be fastened parallel or perpendicular to the front as shown Figure 5.

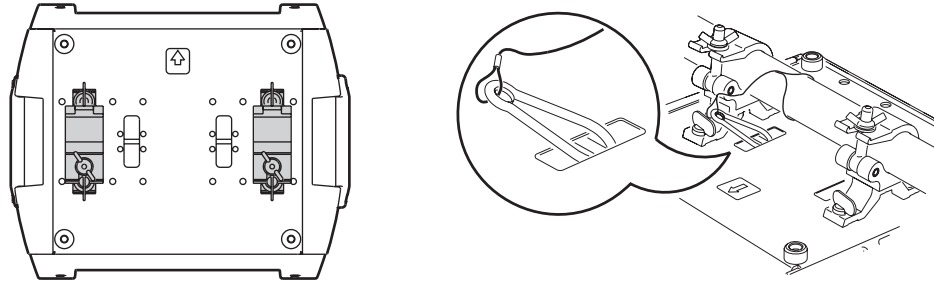

Figure 5: Clamp bracket positions and safety wire attachment point



DANGER! Use two clamps to rig the fixture. Lock each clamp by turning both 1/4-turn fasteners fully clockwise. Attach an approved safety cable to the attachment point labelled “SAFETY WIRE” in the base. Do not use the carrying handles for secondary attachment.

To clamp the fixture on a truss

1. Check that the rigging clamps are undamaged and can bear at least 10 times the weight of the fixture. Check that the structure can bear at least 10 times the weight of all installed fixtures, clamps, cables, auxiliary equipment, etc.
2. Bolt each clamp securely to a clamp bracket with a minimum grade 8.8 M12 bolt and lock nut.
3. Align a clamp with 2 mounting points in the base. Insert the fasteners into the base and turn both levers a full 1/4-turn clockwise to lock. Install the second clamp.
4. Block access under the work area. Working from a stable platform, hang the fixture on the truss with the arrow on the base towards the area to be illuminated. Tighten the rigging clamps.
5. Install a safety wire that can bear at least 10 times the weight of the fixture. The attachment point is designed to fit a carabiner clamp.
6. Check that the tilt lock is released.
7. Check that there are no combustible materials or surfaces to be illuminated within 0.5 m (20 in.) of the fixture, and that there are no flammable materials nearby.
8. Allow a center-to-center distance of 550 mm (21.7 in.) minimum between MAC TW1 fixtures. Increase this distance if accessories are fitted to the front of the head. Check that heads will not collide with other fixtures.

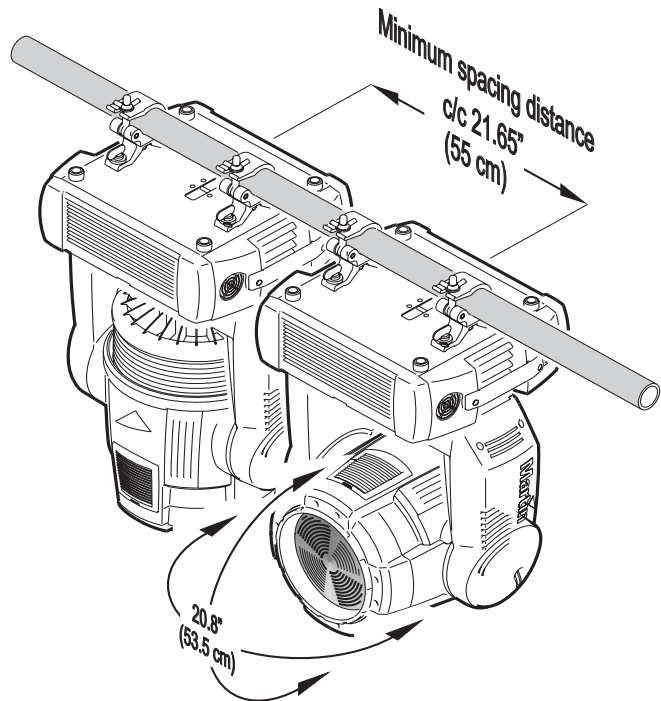

Figure 6: Head movement and fixture spacing

Setup



DANGER! Read “Safety Information” on page 3 before installing, powering, operating or servicing the MAC TW1.

Important! Leave the MAC TW1 powered on for 20 minutes after dousing the lamp so that cooling fans can reduce the temperature of the fixture. Failure to do so will result in excessive heat buildup and may cause damage that is not covered by the product warranty.

Control panel

You can set the MAC TW1’s DMX address, configure individual fixture settings (personality), read out data, and execute service utilities from the fixture’s control panel. Settings can also be changed remotely via the DMX link with the Martin MP-2 uploader.

See “Control menu” starting on page 30 for a complete list of the menus and commands available in the control panel.

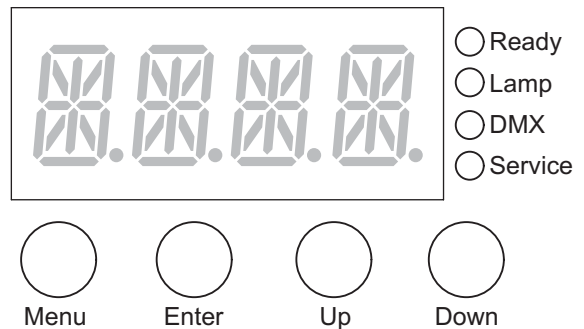

Figure 7: Control panel

Menu navigation

The DMX address and any status messages (see page 34) are displayed on the control panel when the MAC TW1 is powered on. To enter the menu, press [Menu]. Press [Up] and [Down] to move within the menu. To select a function or submenu, press [Enter]. To escape a function or menu, press [Menu].

Note: [Enter] must be pressed and held for a few seconds to enter the Utilities menu (*UTIL*).

DMX address and protocol

The DMX address, also known as the start channel, is the first channel used to receive instructions from the controller. For independent control, each fixture must be assigned its own control channels. Two MAC TW1s may share the same address, however, if identical behavior is desired. Address sharing can be useful for diagnostic purposes and symmetric control, particularly when combined with the inverse pan and tilt options.

Depending on the selected DMX mode, the MAC TW1 requires 14 or 20 DMX channels. 16-bit basic mode uses 14 channels and provides coarse control of all effects plus fine control of pan and tilt. 16-bit extended mode uses 20 channels and provides the basic mode features plus fine control of electronic and mechanical dimmers, cyan, magenta, yellow and zoom.

DMX addressing is limited to channels 1-499 in basic mode and 1-493 in extended mode. This makes it impossible to set the DMX address so high that you are left without enough control channels for the fixture.

To set DMX address and basic or extended mode

1. Press [Menu] to enter the main menu.
2. Press [Up] or [Down] until *ADDR* is displayed. Press [Enter]. To snap to channel 1, press [Enter] and [Up]. Scroll to the desired channel and press [Enter]. Press [Menu] to return to the first level of the main menu.
3. Press [Up] or [Down] until *PSET* is displayed. Press [Enter]. Select *16BT* for basic mode, or *16EX* for extended mode. Press [Enter].

Tailoring performance

MOVEMENT

The MAC TW1 provides several options for optimizing movement for different applications.

- The protocol setting (*PSET*) setting selects 16-bit basic (*16BT*) or extended (*16EX*) control mode. Extended mode uses 6 additional DMX channels to provide fine control of the electronic and mechanical dimmers, cyan, magenta, yellow and zoom lens.
- The pan and tilt invert (*PATI*) menu swaps and/or inverts pan and tilt.
- The pan/tilt speed (*PTSP*) menu provides 2 settings: *FAST* and *NORM*. The *NORM* (normal) setting gives smoothest pan/tilt movement during slow scene changes and quietest operation. It is best for most applications and is the default setting. *FAST* provides better performance in applications where speed is most important.
- The effects speed (*EFSP*) menu provides 3 settings: *PTSS*, *NORM* and *FAST*. If set to *PTSS* (pan/tilt speed slave), effects speed follow the pan/tilt speed set in the *PTSP* menu. This is the default setting. As with pan/tilt speed, *NORM* gives smoothness and silence. *FAST* gives extra speed.
- The pan/tilt and effects speed settings described above are overridden if studio or silent modes are selected in the *PERS*→*MODE* menu.
- The shortcuts (*PERS*→*SCUT*) setting determines whether the CMY filters take the shortest path between two positions, crossing the open position if necessary, or always avoid the open position.

DISPLAY

The display on/off setting (*PERS*→*DISP*) determines whether the display remains on (*ON*), remains on for 2 minutes after the last key press (*2MN*), or remains on for 10 minutes after the last key press (*10MN*).

The display intensity (*PERS*→*DIINT*) setting controls display brightness. Select *AUTO* for automatic display or manually set the intensity to a level from *10* to *100*.

To invert the display when the fixture is installed base up, press [Up] and [Down] simultaneously.

DMX RESET

The DMX reset (*PERS*→*DRRES*) setting controls the behavior of the reset command. When set to *ON*, the command is fully enabled. When set to *OFF*, the command is disabled to prevent accidental resets. When set to *5SEC*, the command must be sent for five seconds. The special combination of DMX values listed under channel 1 on page 28 allows you to execute a reset even when the command is disabled.

DIMMER

The dimmer curve setting (*PERS*→*DIICU*) provides three options for dimming characteristics:

- *LIN*, the default setting, gives a linear dimming curve.
- *SQR* or square law dimming, gives a dimming curve with higher fader resolution (finer control) at low light intensity levels and lower fader resolution (coarser control) at high intensity levels.
- *ISQR* or inverse square law dimming, gives a dimming curve with higher fader resolution (finer control) at high light intensity levels and lower fader resolution (coarser control) at low intensity levels.

NOISE REDUCTION MODE

The noise reduction mode (*PERS*→*MODE*) setting gives three options for tailoring movement and cooling fan speed to give varying degrees of quiet operation:

- When set to *NORM*, pan/tilt, effects and fans obey their settings entered elsewhere in the control menus.
- When set to studio mode (*STUD*), pan/tilt and effects speed are set to *NORM* and fan speed is temperature-regulated.
- When set to quiet mode (*SLNT*), pan/tilt and effects are set to slow movement and fan speed is set to *OFF* as described in "Cooling and noise control" on page 20.

STUD and *SLNT* modes override pan/tilt, effects and fan speed settings entered elsewhere in the control menus.

LAMP MANAGEMENT

The preheat (*PERS*→*HEAT*) setting preheats the lamp by maintaining from 0 - 20% lamp power when the lamp is dimmed. Higher preheat settings give faster lamp reaction when the electronic dimmer is bumped

up. Preheating does not seriously reduce lamp lifetime unless engaged for very long periods, but it requires higher cooling fan speeds.

The economy mode (*PERS*→*ECON*) setting limits lamp power to maximum to between 70% and 100% of full power when the electronic dimmer operates at full intensity. If full power is never required, limiting lamp power is an effective way of increasing lamp lifetime. Too many factors determine lamp lifetime for a precise figure to be given, but a very approximate rule is that a 5% reduction in lamp power will double lamp lifetime.

The MAC TW1 monitors lamp operation when an internal dimmer is used. If a lamp fails, *LAE X* appears in the fixture's display and the fixture enters lamp explosion mode, in which pan and tilt are locked and the fixture does not respond to DMX control. If *LAE X* is displayed, cut power to the fixture and do not operate it until you have checked the lamp for burnt-out filaments or damage and replaced if necessary. Pan and tilt are released and DMX control is re-enabled when power is reapplied.

CUSTOM SETTINGS

The custom configuration function *DFSE*→*CUS 1- CUS 3* allows you to save and recall three sets of fixture settings. The savable settings are DMX mode, pan/tilt speed, pan/tilt inverse and swap, display, DMX reset, shortcuts, dimming curve, lamp pre-heat and economy modes, noise reduction modes and effects speed.

All settings can be returned to factory defaults using the *DFSE*→*FAC T*→*LOAD* command.

Readouts

TIME

INFO→*TIME* provides readouts of fixture hours (*HRS*) and lamp hours (*L HR*). For each of these readouts, there is a resettable (*RSET*) and a non-resettable (*TOTL*) counter for total accumulated hours since fabrication. To return the resettable counter to zero, display it and then press [Up] until the counter reads 0.

Because the lifetime of the tungsten halogen lamp is greatly extended when the lamp is at less than 100% intensity, the number of hours displayed in the lamp hours counter can only be used as an approximate guide when considering lamp replacement (see also the section on economy mode above).

TEMPERATURE

INFO→*TEMP* provides temperature readouts for the head and base.

FIRMWARE VERSION

INFO→*VER* displays the version number of the installed firmware. The firmware version is also displayed briefly at startup.

FANS

INFO→*FANS* displays the current speed of base, head and lamp cooling fans in RPM (revolutions per minute).

DMX

The DMX log (*DMXL*) menu provides useful information for troubleshooting control problems.

RATE displays the DMX refresh rate in packets per second. Values lower than 10 or higher than 44 may result in erratic performance, especially when using tracking mode.

QUAL displays the quality of the received DMX data as a percentage of packets received. Values much below 100 indicate interference, poor connections, or other problems with the serial data link that are the most common cause of control problems.

STCO displays the DMX start code. Packets with a start code other than 0 may cause irregular performance.

The remaining options under *DMXL* display the DMX values received on each channel. If the fixture does not behave as expected, reading the DMX values can help you troubleshoot the problem.

Manual control

The manual control menu (*MAN*) allows you to:

- reset the fixture (*RST*)
- position and move individual effects (commands are listed on page 31 under 'Control Menu')

Service utilities

Important! *[Enter]* must be held for several seconds to access the utilities menu.

TEST SEQUENCES

TSEQ provides a general test of all effects, allowing testing without a controller.

UTIL→*PCBT* provides routines for circuit board testing that are for service use only.

FEEDBACK TOGGLES

On-the-fly position correction systems monitor pan and tilt as well as the CMY filters. If a position error is detected, the fixture self-corrects. If the system cannot correct the position within 10 seconds, feedback is automatically disabled.

Pan/tilt position correction can be temporarily disabled by setting *UTIL*→*FEBB* to off. CMY position correction can be temporarily disabled by setting *UTIL*→*EFFB* to off. Off settings are not saved, and position correction systems will be re-enabled the next time the fixture starts.

ADJUSTMENT

The adjustment menu (*UTIL*→*ADJ*) provides manual control for making mechanical adjustments. See page 32.

CALIBRATION

The calibration menu (*UTIL*→*CAL*) allows offsets relative to mechanical reset or home positions to be entered in the fixture software. This lets you fine tune optical alignment and achieve uniform performance between fixtures. Dimmer and zoom are calibrated to defined points. The other effects are calibrated relative to an arbitrary reference fixture.

All offsets can be set to *128* (the middle of their adjustment range) with the default offset command: select *UTIL*→*CAL*→*DOF*→*SURE* then press [Enter].

To calibrate effects

1. Apply power but do not apply power to the lamp until zoom has been calibrated.
2. To calibrate zoom, first remove the bottom head cover. Select *UTIL*→*CAL*→*ZDOF* and press [Enter]. Adjust the offset until the face of the zoom lens plate is flush with the back edge of the focus plate. Press [Enter] to save the setting. Replace the bottom head cover.
3. Pan calibration is easiest when multiple fixtures are stacked vertically. To calibrate, set zoom and tilt positions for easy one-over-the-other comparison and set each fixture to the same pan DMX value. Select one fixture to be the reference fixture. On the other fixtures, select *UTIL*→*CAL*→*P DOF* and press [Enter]. Adjust the offset as necessary to align the beam with the reference beam. Press [Enter] to save the setting.
4. Tilt calibration is easiest when multiple fixtures are arranged horizontally. To calibrate, set zoom and pan positions for easy side-by-side comparison and set each fixture to the same tilt DMX value. Select one fixture to be the reference fixture. On the other fixtures, select *UTIL*→*CAL*→*T DOF* and press [Enter]. Adjust the offset as necessary to align the beam with the reference beam. Press [Enter] to save the setting.
5. To calibrate CMY filters, project white beams with no dimming and position them for easy comparison. On each fixture, *including the reference*, select *UTIL*→*CAL*→*C DOF* and press [Enter]. This adds a defined amount of cyan. Select one fixture to be the reference. Adjust the offsets on the other fixtures to match the reference color. Press [Enter] to save the setting. Repeat for *M DOF* (magenta) and *Y DOF* (yellow).

COOLING AND NOISE CONTROL

Cooling fan speed can be set to maximum (*FULL*) or thermostatically regulated (*REG*) via *UTIL*→*FANS*. When set to *REG*, fans run no faster than is necessary, giving reduced noise levels.

At the convection cooling setting *UTIL*→*FANS*→*OFF*, fans are shut down completely whenever convection cooling alone can control fixture temperature. If convection cooling is not sufficient, fans run at thermostatically regulated speed until convection cooling is possible again. As this setting gives totally silent cooling while the lamp is blacked out, dimmed to a low level or when ambient temperature allows, it is recommended for minimum noise levels.

SOFTWARE UPLOAD

The upload mode command (*UTIL*→*UPL D*) prepares the fixture for a software update. This command is not normally necessary, as upload mode is engaged automatically by the uploader.

LED indicators

The four LEDs next to the digital display panel give the following information:

- **Ready** - lights when the fixture has reset and is ready for use.
- **Lamp** - lights when lamp power is applied from the DMX controller, regardless of dimming intensity. If this LED is lit but no light output is present, the mechanical shutter may be closed, the intensity may be dimmed to a very low level, the lamp may have blown, or there may be a problem with the lamp power circuits.
- **DMX** - lights when the fixture is receiving a valid DMX signal.
- **Service** - blinks when the fixture is in factory service mode. For factory use only.

Operation



DANGER! Read “Safety Information” on page 3 before installing, powering, operating or servicing the MAC TW1.

Important! Leave the MAC TW1 powered on for 20 minutes after switching off the lamp so that cooling fans can reduce the temperature of the fixture. Failure to do so will result in excessive heat buildup and may cause damage that is not covered by the product warranty.

This section describes the functions that can be controlled via DMX. See “MAC TW1 DMX protocol” on page 28 for an overview of channels and commands.

The MAC TW1 has two DMX operating modes, 16-bit basic and 16-bit extended. The extended mode requires six more DMX channels than the basic mode and provides all features of the basic mode plus fine control of electronic and mechanical dimmers, cyan, magenta, yellow and zoom.

Where fine control is available, the main control channel sets the first 8 bits (the most significant byte or MSB), and the fine channels set the second 8 bits (the least significant byte or LSB) of the 16-bit control byte. In other words, the fine channel works within the position set by the coarse channel.

Fixture reset

If an effect loses its indexing and fails to move to programmed positions, the fixture can be reset from the controller by sending the “Reset” command on channel 1.

If DMX reset is disabled in the control menu (*PERS*→*IRE*→*OFF*), the reset command can only be executed if the main CMY channels (4, 5 and 6 in basic mode or 6, 8 and 10 in extended mode) are set to a value from 230 to 232. If *PERS*→*IRE* is set to *SSEC*, the reset command must be sent for 5 seconds before it is executed.

Electronic dimming

The internal electronic dimming system is controlled on channel 2, with fine control available in extended mode on channel 3.

If the Lamp Power switch on the connections panel is set to External, the internal electronic dimming channels (2 in basic mode or 2 and 3 in extended mode) are disabled. The external dimmer’s control channel must be set up on the DMX controller following the dimmer manufacturer’s instructions.

Mechanical dimming

The mechanical dimmer/shutter system provides 100 percent dimming, instant open and blackout, and variable speed regular and random strobe effects.

Fine control of the mechanical dimmer is available in extended mode on channel 5.

Cyan, Magenta and Yellow

Cyan, magenta and yellow can be added on channels 4, 5 and 6 in basic mode or 6, 8 and 10 in extended mode. Fine control of CMY is available on channels 7, 9 and 11 in extended mode.

Zoom

The zoom lens varies the one-tenth peak angle from 19° to 41° (precise angle limits depend on lamp type) using channel 7 in basic mode or 12 in extended mode. Fine control of zoom is available in extended mode on channel 13.

Pan and tilt

Pan and tilt are controlled on channels 8 to 11 in basic mode or 14 to 17 in extended mode. Coarse and fine control are available in both basic and extended modes.

Pan/tilt speed and effects speed channels

TRACKING VERSUS VECTOR CONTROL

Important! *Effect movement may be rough and unpredictable if controller fade times are combined with vector speed values.*

The pan/tilt and effects speed channels 12 and 13 in basic mode or 18 and 19 in extended mode provide two methods for controlling the speed at which effects move that are known as “tracking” and “vector”.

if you select tracking mode, pan/tilt and effects speed is determined by the cross-fade time programmed on the controller. With this method, the controller divides a movement into tiny steps that the fixture “tracks”, or follows.

If you select vector mode, pan/tilt and effects speed is determined by the DMX value you send on the speed channel. Vector mode allows you to control the speed of scene changes on controllers without cross-faders. It can give smoother movement, particularly at slow speeds, when using a controller that sends slow or irregular tracking updates.

If the DMX controller has variable cross-fade times, set them to zero when using vector mode.

PERSONALITY OVERRIDES

Using the pan/tilt speed channel, you can set pan/tilt to tracking mode and at the same time set the fixture's own pan/tilt speed setting to normal or fast from the DMX controller, overriding the pan/tilt speed setting available in the fixture's control menus.

Using the effects speed channel, you can set the CMY filters to tracking and at the same time set shortcuts to on or off from the DMX controller, overriding the shortcuts setting available in the fixture's control menus.

Control menu settings

Channel 14 in basic mode or 20 in extended mode gives control via DMX of a range of settings that are otherwise only available via the fixture's control panel. This can be very convenient in situations where access to the fixture is difficult. The following settings are available:

- A dimmer curve from 1 - 5 can be selected.
- Lamp preheat can be enabled or disabled (the preheat power value must be entered via the fixture's control panel)
- Economy mode can be enabled (the percentage reduction in lamp power must be set via the fixture's control panel)
- Fan speed can be set to full, temperature-regulated or off. If set to off, convection cooling is used whenever possible and fans will only run if absolutely necessary.
- Noise reduction mode can be set to Normal, Studio or Quiet.

Using the DMX controller to change settings on the control menu settings channel has the same effect as changing those settings using the fixture's control panel. Like settings made using the control panel, they are retained in the fixture's memory after the fixture is powered off and on.

Important! *To engage one of the above control menu settings, the required DMX value must be held for 3 seconds and then reduced to a *No function* DMX value between 0 and 19.*

Service and maintenance

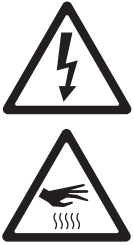

DANGER! Read “Safety Information” on page 3 before servicing the MAC TW1. Disconnect the fixture from power and allow to cool for 45 minutes before handling or removing any cover. Refer any service operation not described here to a qualified service technician.

Important! Excessive dust, smoke fluid, and particle buildup degrades performance, causes overheating and will damage the fixture. Damage caused by inadequate cleaning or maintenance is not covered by the product warranty.

As with electronic components in general, the MAC TW1’s PCBs are sensitive to ESD (electrostatic discharge). The IGBT dimmer is particularly sensitive. Take precautions to avoid ESD damage before opening the fixture. Service electronic components at a static-safe workstation only.

It is Martin policy to use the best-quality materials and coatings available to ensure optimum performance and the longest possible component lifetimes. However, optical components in all lighting fixtures are subject to wear and tear over the life of the fixture, resulting in gradual changes in color rendition of dichroic filters or the specular properties of reflectors, for example.

The extent of wear and tear depends heavily on operating conditions, maintenance and environment, so it is impossible to specify precise lifetimes for optical components. However, you will eventually need to replace optical components if their characteristics are affected by wear and tear after an extended period of use and if you require fixtures to perform within very precise optical and color parameters.

To maximize the life of the MAC TW1 and protect the investment it represents, clean the fixture regularly – especially the cooling systems – following the guidelines in this section.

Tilt lock

Important! Release the tilt lock before operating the fixture.

The tilt position of the head can be locked for transportation and service with the tilt lock. To lock or unlock the head, move the lock knob to the correct position as shown in Figure 8.

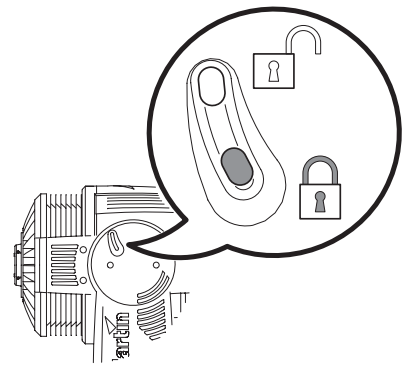
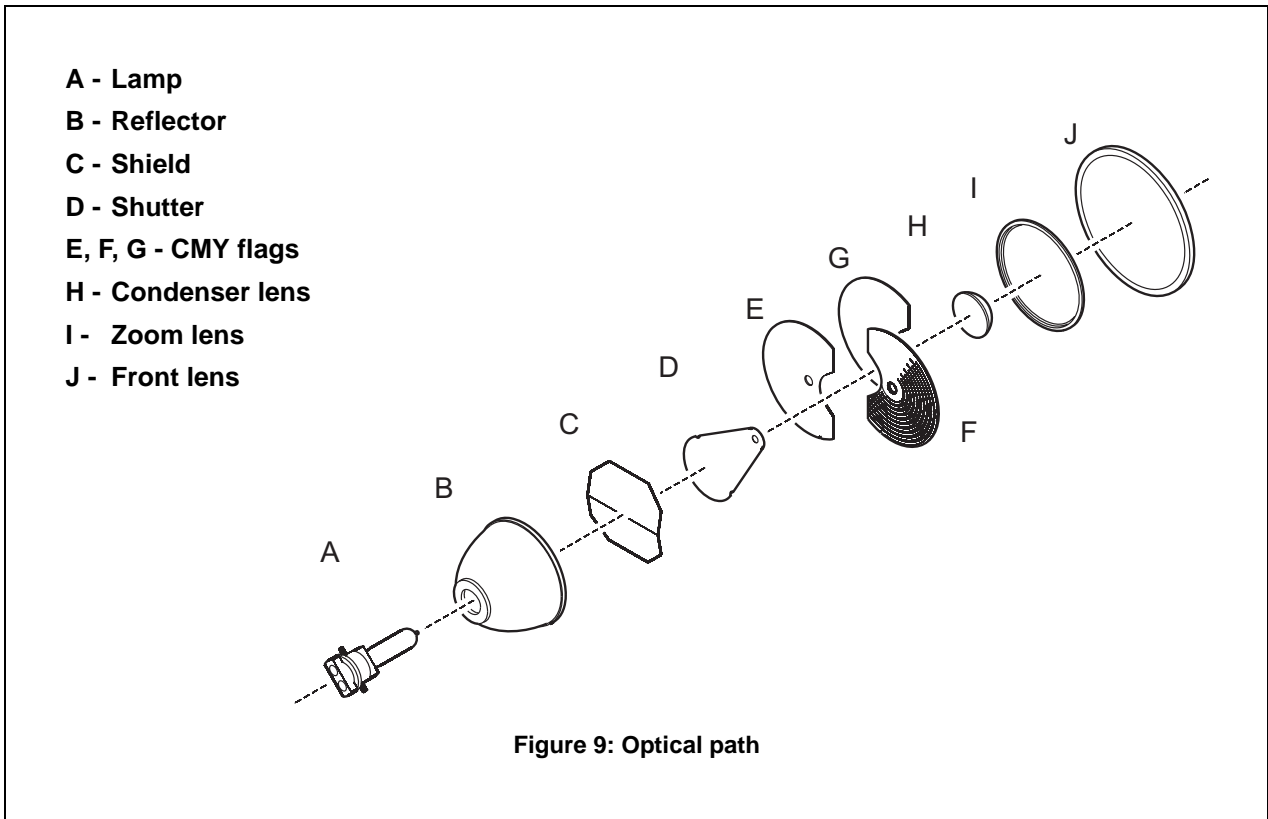

Figure 8: Tilt lock

Optical path



Accessing and removing effects components



To gain access to the optical and effects components in the head for cleaning and access:

1. Disconnect the fixture from power and allow it to cool for 45 minutes.
2. Turn the 4 retaining screws in the top cover (see Figure 10) one half-turn counter-clockwise to release the cover. Covers are a tight fit on the MAC TW1, and the top cover may require some pressure to remove.

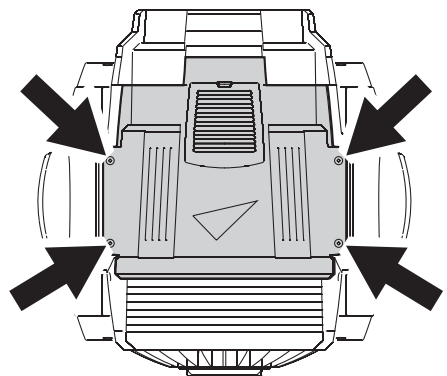

Figure 10: Top cover retaining screws

To remove the effects module:

1. Remove the four retaining screws from the front lens ring (see Figure 11) and remove the front lens.

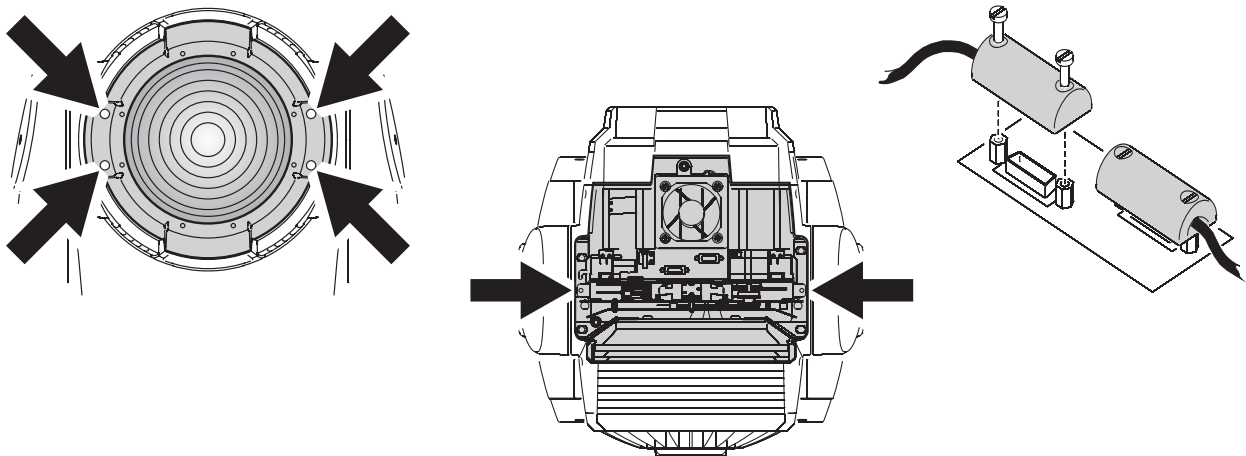

Figure 11: Removing the effects module

2. Remove the two retaining screws on the outside edges of the module to release it.
3. Loosen the screws in the two module wireset connectors as shown in Figure 11 before lifting the module away from the fixture.

When reinstalling the effects module, check that the guide pins are correctly seated, that the module is securely screwed into position and that the screws in the two cable connectors are tight. The module is fitted with LEDs that light to indicate that the CMY filters are in their correct positions.

Cleaning

Regular cleaning is essential for fixture life and performance. Buildup of dust, dirt, smoke particles, fog fluid residues, etc. degrades the fixture's light output and cooling ability.

Cleaning schedules for lighting fixtures vary greatly depending on the operating environment. It is therefore impossible to specify precise cleaning intervals for the MAC TW1. Cooling fans suck in airborne dust and smoke particles, and in extreme cases fixtures may require cleaning after surprisingly few hours of operation. Environmental factors that may result in a need for frequent cleaning include:

- Use of smoke or fog machines.
- High airflow rates (near air conditioning vents, for example).
- Presence of cigarette smoke.
- Airborne dust (from stage effects, building structures and fittings or the natural environment at outdoor events, for example).

If one or more of these factors is present, inspect fixtures within their first 25 hours of operation to see whether cleaning is necessary. Check again at frequent intervals. This procedure will allow you to assess cleaning requirements in your particular situation. If in doubt, consult your Martin dealer about a suitable maintenance schedule.

Use care when cleaning optical components and work in a clean, well lit area. The coated surfaces are fragile and easily scratched. Do not use solvents that can damage plastic or painted surfaces.

To clean the fixture



Warning! Disconnect from power and allow to cool before cleaning.

1. Disconnect the fixture from power and allow it to cool for at least 45 minutes.
2. Remove the covers and CMY module as described earlier.
3. Vacuum or gently blow away dust and loose particles with compressed air.
4. Carefully clean the optical components. Remove smoke and other residues with cotton swabs or unscented tissues moistened with isopropyl alcohol. A commercial glass cleaner may be used, but residues must be removed with distilled water. Clean with a slow circular motion from center to edge. Dry with a clean, soft and lint-free cloth or compressed air. Remove stuck particles with an unscented tissue or cotton swab moistened with glass cleaner or distilled water. Do not rub the surface: lift the particles off with a soft repeated press.

5. Remove dust from the head with a soft brush, cotton swab, vacuum, or compressed air. Pay special attention to fans and air vents.
6. Reassemble the head.
7. Remove the screws from the side cover/grill on the front of the base (front is indicated by an arrow on the bottom). Remove the top cover from the front of the base. Lift the power supply / ballast module up and out to expose the base fans for inspection and cleaning.
8. Reinstall the power supply / ballast module and base cover.

Cleaning the air filters

1. See Figure 12. On each side of the head, push on the retaining tab to unclip and remove the 2 air filter covers.
2. In each cover, pull up on tab A and lift the retaining clip up and forward to disengage tab B.

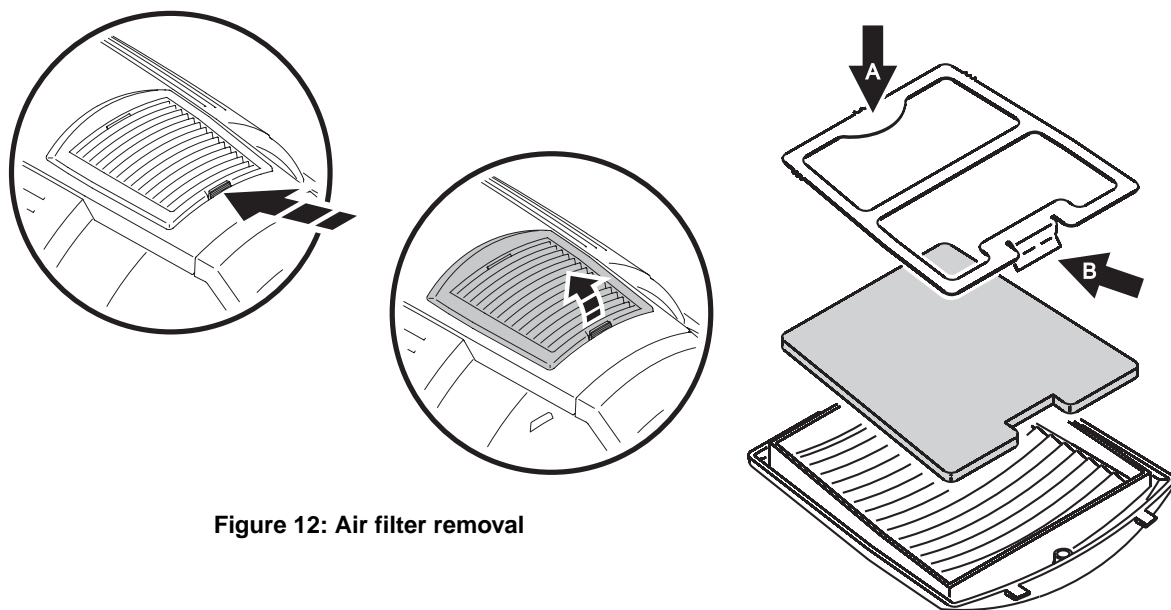

Figure 12: Air filter removal

3. Remove and clean the air filters. If they are saturated with smoke fluid, soak them in warm soapy water and blot dry. If the filters cannot be cleaned completely or are not in perfect condition, replace them.
4. Replace each filter in its cover, then replace the retaining clips, engaging tab B in its slot and pushing down on tab A to secure.
Important! Make sure filter retaining clips are correctly fitted and secure, or the filters will be sucked into the fixture and cause overheating.
5. Clip the filter covers back into place on the head.

Lubrication

In general, the MAC TW1 does not require lubrication. However, depending on use conditions, the bronze bushes and slider bars for the zoom lens car may require reapplication of the long-lasting teflon-based grease applied at the factory. Noise when operating the zoom is a sign that lubrication is required. This operation can be carried out by a Martin service partner if necessary.

Do not lubricate plastic bushes.

Fuse replacement



DANGER! Disconnect from power and external dimmer before opening covers. Replace fuses with ones of the same type and rating only.

Important! The PCBs are sensitive to ESD (electrostatic discharge). Take precautions to avoid ESD damage. Avoid touching electronic components.



The MAC TW1 is protected by two main fuses, one on the live and one on the neutral conductor. The fuses are located on the PCB in the base unit. The circuit that supplies lamp power from an external dimmer is also protected by two fuses. All four fuses are 20 amp, slow-blow type.

To replace fuses:

1. Disconnect the fixture from power and the external dimmer system, if used, and allow to cool for 45 minutes.
2. Take precautions to avoid damage by static discharge.
3. See Figure 13. Remove the four screws (arrowed) from the outer edges of the connections panel cover and pull the cover away from the fixture base for access to the PCBs.

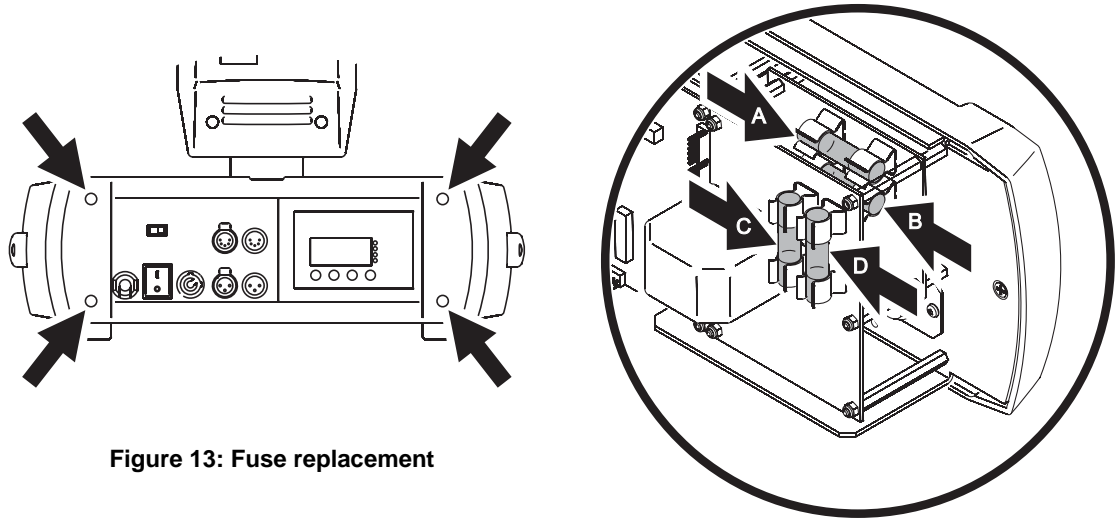

Figure 13: Fuse replacement

4. See Figure 13. Fuses marked A and B protect the main power circuit. Fuses C and D protect the external dimmer lamp power circuit.
5. Replace defective fuses with ones of the same type and rating only. Fuses are available from Martin, P/N 05020051.
6. Replace and secure the connections panel cover before reapplying power or reconnecting an external dimmer system.

Software installation

Software updates are available from the Martin web site and can be installed via the data link with a Martin upload device.

The following are required in order to install software.

- The MAC TW1 update file, available for download from the User Support Area of the Martin web site at <http://www.martin.com/service>
- The Martin Software Uploader program, version 5.0 or later, available for download from the User Support Area of the Martin web site.
- A Martin MP-2 Uploader connected to a Windows 95/98/ME/2000/XP PC, or one of the PC controller DMX interfaces supported by the Martin Software Uploader software.

To install software, normal method

Please refer to the MP-2 user manual and the Martin Software Uploader online help file.

To install software if all else fails (boot sector update)

Note: Use this procedure only if the firmware is totally corrupted, which is evident if the control panel does not respond when power is applied, or if the software update notes call for a boot sector update. In the event of a check sum error, repeat the normal upload procedure.

1. Disconnect the fixture from power.
2. Remove the side cover from the side of the base that has the control panel to expose the main PCB.
3. Locate the "BOOT" jumper on the main PCB (see page 36) and move the jumper cap to the "INIT" position.
4. Perform a boot mode upload as described in the uploader documentation.
5. When the upload is complete, disconnect the fixture from power and move the jumper back to the "DISABLE" position.
6. Reassemble the base.

MAC TW1 DMX protocol

16-bit Basic Mode	16-bit Extended Mode	DMX Value	Percent	Function
1	1	0 - 19	0 - 7	Shutter, strobe, reset, lamp on/off Shutter closed
		20 - 49	8 - 19	Shutter open
		50 - 72	20 - 28	Strobe, fast → slow
		73 - 127	29 - 50	Shutter open
		128 - 147	51 - 57	Random strobe, fast
		148 - 167	58 - 65	Random strobe, medium
		168 - 187	66 - 73	Random strobe, slow
		188 - 207	74 - 81	Shutter open
		208 - 217	82 - 85	Reset fixture*
		218 - 255	86 - 100	Shutter open
2	2	0 - 255	0 - 100	Electronic dimmer Blackout → 100% intensity
				Electronic dimmer, fine Low → high intensity
-	3	0 - 255	0 - 100	Electronic dimmer, fine Low → high intensity
3	4	0 - 255	0 - 100	Mechanical dimmer Blackout → 100% intensity
				Mechanical dimmer, fine Low → high intensity
-	5	0 - 255	0 - 100	Mechanical dimmer, fine Low → high intensity
4	6	0 - 255	0 - 100	Cyan White → full cyan
				Cyan, fine Add cyan
-	7	0 - 255	0 - 100	Cyan, fine Add cyan
5	8	0 - 255	0 - 100	Magenta White → full magenta
				Magenta, fine Add magenta
-	9	0 - 255	0 - 100	Magenta, fine Add magenta
6	10	0 - 255	0 - 100	Yellow White → full yellow
				Yellow, fine Add magenta
-	11	0 - 255	0 - 100	Yellow, fine Add magenta
7	12	0 - 255	0 - 100	Zoom Flood → spot
				Zoom, fine Wide → narrow
-	13	0 - 255	0 - 100	Zoom, fine Wide → narrow
8	14	0 - 255	0 - 100	Pan Full left → full right (128 = neutral)
				Pan, fine Left → right
-	15	0 - 255	0 - 100	Pan, fine Left → right
10	16	0 - 255	0 - 100	Tilt Full tilt → full opposite tilt (128 = neutral)
				Tilt, fine Tilt → opposite tilt
-	17	0 - 255	0 - 100	Tilt, fine Tilt → opposite tilt
12	18	0 - 2	0 - 1	Pan/tilt speed Tracking mode
		3 - 245	1 - 95	Vector mode, fast → slow
		246 - 248	96 - 97	Tracking mode, <i>PTSP = NORM</i> (overrides speed set via control menu)
		249 - 251	97 - 98	Tracking mode, <i>PTSP = FAST</i> (overrides speed set via control menu)
		252 - 255	99 - 100	Blackout while moving

*If disabled under *PERS* → *RES* in the control menu, **Reset fixture** works only if the three main CMY channels are set to a value from 230 to 232. A five-second delay for the **Reset fixture** command can be set in the control menu under *RES*.

Table 2: DMX Protocol

16-bit Basic Mode	16-bit Extended Mode	DMX Value	Percent	Function
13	19	0 - 2	0 - 1	Effects speed
		3 - 245	1 - 96	<i>CMY filters</i>
		246 - 248	96 - 97	Tracking mode
		249 - 251	98	Vector mode, fast → slow
		252 - 255	99 - 100	Tracking mode, <i>SCUT</i> = OFF (overrides ON if set via control menu)
				Tracking mode, <i>SCUT</i> = ON (overrides OFF if set via control menu)
				Vector mode, fast
				Zoom
		0 - 2	0 - 1	Tracking mode
		3 - 245	1 - 96	Vector mode, fast → slow
		246 - 255	97 - 100	Vector mode, fast
14	20	0 - 19	0 - 7	Control menu settings
		20 - 29	8 - 11	No function
		30 - 39	12 - 15	Linear dimmer curve
		40 - 49	16 - 19	Square law dimmer curve
		50 - 59	20 - 23	Inverse square law dimmer curve
		60 - 69	24 - 27	No function: reserved for future use
		70 - 79	28 - 31	No function: reserved for future use
		80 - 89	32 - 35	Preheat on
		90 - 99	36 - 39	Preheat off
		100 - 109	40 - 43	Economy mode on (extended lamp life)
		110 - 119	44 - 47	Economy mode off (higher light output)
		120 - 129	48 - 51	Fan speed full (maximum cooling)
		130 - 139	52 - 55	Fan speed regulated (minimum noise)
		140 - 149	56 - 58	Fans off (if conditions allow)
		150 - 159	59 - 62	Normal mode
		160 - 169	63 - 66	Studio mode
		170 - 255	67 - 100	Quiet mode
			No function: reserved for future use	

These settings replace existing settings in the fixture's control menus. All values must be held for 3 seconds and then returned to 'No function' in order to engage the setting. Settings are retained in memory after powering off.

Table 2: DMX Protocol

Control menu

Menu	Item	Options	Notes (Default settings in bold print)
ADDR		1 - 490 (16-bit basic)	DMX address (new fixtures are supplied with address set to 1)
		1 - 482 (16-bit extended)	
PSET		16BT	16-bit basic DMX mode with 2-channel (coarse and fine) control of pan and tilt
		16EX	16-bit extended DMX mode with basic mode features plus fine control of electronic and mechanical dimmers, cyan, magenta, yellow and zoom
PATI	SWAP	OFF	Normal pan and tilt control
		ON	Map DMX pan control to tilt channel and vice versa
	PINV	OFF	Normal pan control: left → right
		ON	Reverse DMX pan control: right → left
	TINV	OFF	Normal tilt control: up → down
		ON	Reverse DMX tilt control, down → up
PTSP		NORM	Normal pan/tilt speed
		FAST	Optimize pan/tilt movement for speed
EFSP		NORM	Normal effects speed
		FAST	Optimize effects movement for speed
		PTSS	Pan/tilt speed slave: effects speed copies the pan/tilt speed set via the control menu or via DMX
PERS	DISP	ON	Display remains on
		2 MN	Display goes into sleep mode 2 minutes after last key press
		10MN	Display goes into sleep mode 10 minutes after last key press
	DINT	AUTO	Display adjusts automatically for ambient light level
		100 - 10	Adjust display intensity manually
	DRES	ON	Enable reset via DMX
		OFF	Disable reset via DMX
		5SEC	Enable reset via DMX when reset command is held for 5 seconds
	SCUT	ON	CMY filters move shortest distance (across open)
		OFF	CMY filters do not cross open
	DICU	LIN	Linear dimming curve (VRMS: voltage root mean square)
		SQR	Square law dimming curve
ISQR		Inverse square law dimming curve	
MODE	NORM	Normal mode: pan, tilt and effects set to normal speed, fans obey control menu (UTIL → FANS) setting	
	STUD	Studio mode: pan, tilt and effects set to normal speed, fans set to temperature-regulated (overrides other control menu settings)	
	SLNT	'Silent' mode: pan, tilt and effects set to slow speed, fans set to off (overrides other control menu settings)	
HEAT	ENA	ON / OFF Enable lamp pre-heat (OFF by default)	
	VAL	0 - 20 0.0 - 20.0% lamp preheat value (1.0% by default)	
ECO	ENA	ON / OFF Enable economy mode: reduced lamp power (OFF by default)	
	VAL	70 - 100 70 - 100% lamp power value (80% by default)	
DFSE	FACT	LOAD	Return all settings (except calibrations) to factory defaults
	CUS1, CUS2, CUS3	LOAD	Load custom configuration
		SAVE	Save current custom configuration

Table 3: Control menu

Menu	Item	Options	Notes (Default settings in bold print)
INFO	TIME→HRS	TOTL	Total hours of operation since manufacture
		RSET	Hours of operation since counter reset (see page 18)
	TIME→L HR	TOTL	Total hours of lamp operation since manufacture
		RSET	Hours of lamp operation since counter reset (see page 18)
	TEMP	HEAD	Head temperature
		BASE	Base temperature
	VER	X.X.X	CPU firmware version
	FANS	BASE	Base cooling fans speed readout (RPM)
		HEAD	Head cooling fans speed readout (RPM)
LAMP		Lamp cooling fans speed readout (RPM)	
DMXL	RATE		DMX transmission speed in packets per second
	QUAL		Percent of packets received
	STCO		Value of the DMX start code
	SHUT - CTRL		DMX value (0 - 255) received on each channel Values for coarse control are indicated with C in the display Values for fine control channels (indicated with F in the display) can only be viewed if available in the DMX mode the fixture is set to
MAN	RST		Reset fixture
	SHUT	OPEN	Open shutter
		CLOS	Close shutter
		STRF	Fast shutter strobe
		STRM	Medium shutter strobe
		STRS	Slow shutter strobe
	EDIM	0 - 255	Electronic dimmer
	MDIM	0 - 255	Mechanical dimmer
	CYAN	0 - 255	Cyan
	MAG	0 - 255	Magenta
	YEL	0 - 255	Yellow
	ZOOM	0 - 255	Zoom position
	PAN	0 - 255	Pan position
TILT	0 - 255	Tilt position	
TSEQ	RUN		Run test of all effects (service use only)

Table 3: Control menu

Menu	Item	Options	Notes (Default settings in bold print)
UTIL To access this menu, hold [Enter] pressed for a few seconds	FE]B	ON	Enable pan/tilt position feedback/correction system. See page 19
		OFF	Disable pan/tilt feedback. Setting not saved
	EFF]B	ON	Enable CMY filter position feedback/correction system. See page 19
		OFF	Disable CMY filter position feedback. Setting not saved
	ADJ	EFF	Effects adjustment menu (for service use: see "Adjustment submenu" on page 33)
	CAL (OF = offset)	P OF	Pan calibration (adjustment range: 1 - 255)
		T OF	Tilt calibration (adjustment range: 70 - 186)
		C OF	Cyan calibration (adjustment range: 1 - 255)
		M OF	Magenta calibration (adjustment range: 1 - 255)
		Y OF	Yellow calibration (adjustment range: 1 - 255)
		ZOOF	Zoom calibration (adjustment range: 98 - 158)
]FOF	SURE	Load factory effects calibration settings
	PC]T	SURE	PCB test: for service use only
	FANS	FULL	Cooling fans: full speed
		REG	Cooling fan speed temperature-regulated
		OFF	Cooling fans: off whenever possible
	UPL]J	SURE	Manually set fixture to software update mode

Table 3: Control menu

Control panel shortcuts

The following shortcuts are available using the buttons in the MAC TW1 control panel:

Shortcut	Function
Hold [Menu] and press [Up]	Resets fixture
Hold [Menu] and [Enter] during fixture reset	Freezes pan and tilt
Hold [Up] and press [Down]	Invert display

Table 4: Control panel shortcuts

Adjustment submenu

The *UTIL→ADJ* menu is for use by service technicians when performing adjustments.

Item	Options	Notes	
<i>RST</i>		Reset fixture	
<i>HEAD</i>	<i>CYAN</i>	<i>ON S</i>	Cyan effect on switch
		<i>MIN</i>	Minimum cyan position
		<i>MAX</i>	Maximum cyan position
		<i>CW S-CCWF</i>	Cyan rotation clockwise slow - counterclockwise fast
	<i>MAG</i>	<i>ON S</i>	Magenta effect on switch
		<i>MIN</i>	Minimum magenta position
		<i>MAX</i>	Maximum magenta position
		<i>CW S-CCWF</i>	Magenta rotation clockwise slow - counterclockwise fast
	<i>YEL</i>	<i>ON S</i>	Yellow effect on switch
		<i>MIN</i>	Minimum yellow position
		<i>MAX</i>	Maximum yellow position
		<i>CW S-CCWF</i>	Yellow rotation clockwise slow - counterclockwise fast
	<i>SHUT</i>	<i>ADJ</i>	Shutter adjustment position
		<i>CLOS</i>	Shutter closed
		<i>OPEN</i>	Shutter open
		<i>SLOW</i>	Slow shutter strobe
		<i>MED</i>	Medium shutter strobe
		<i>FAST</i>	Fast shutter strobe
	<i>ZOOM</i>	<i>ON S</i>	Zoom module positioned on switch
		<i>NEAR</i>	Zoom near position
<i>FAR</i>		Zoom far position	
	<i>TEST</i>	Test all effects in effects module: service use only	
<i>PATI</i>	<i>NEUT</i>	Pan and tilt neutral positions	
	<i>PNTD</i>	Pan neutral, tilt down	
	<i>PNTU</i>	Pan neutral, tilt up	
	<i>PLTN</i>	Pan left, tilt neutral	
	<i>PRTN</i>	Pan right, tilt neutral	
	<i>PLTD</i>	Pan left, tilt down	
	<i>PRTU</i>	Pan right, tilt up	

Table 5: Adjustment submenu

Display messages

Message	Appears when...	What to do
<i>RST</i> (Reset)	... the fixture is indexing effects at startup.	Wait for reset to complete.
<i>SRST</i> (Serial reset)	... the fixture has received a reset command via DMX.	Wait for reset to complete. Note that you can set <i>PERS</i> → <i>RES</i> to <i>OFF</i> to prevent accidental DMX reset commands.
■ ■ ■ ■ or * * * *	...there is no communication between the control panel and motherboard (this display appears briefly when powering the fixture on).	Check fuses. Check cable and connectors between control panel and motherboard. Reinstall fixture software. Contact Martin service if the above do not solve the problem.
<i>MERR</i> (Memory error)	...the EEPROM memory cannot be read.	Contact Martin service personnel for assistance.
<i>FDEP</i> (Feedback error pan) <i>FDET</i> (Feedback error tilt) <i>FDER</i> (Feedback error pan/tilt)	...the pan and/or tilt correction systems cannot correct a loss of step (or there is a malfunction in the pan/tilt monitoring circuit such as a defective sensor). After a time-out, the head stops in a random position.	Reset fixture. Contact Martin service personnel if problem continues.
<i>PAER</i> (Pan time-out) <i>TIER</i> (Tilt time-out) <i>ZDER</i> (Zoom time-out)	...there is a malfunction in the position indexing circuit for pan, tilt or zoom. The fixture will, after the time-out, establish a mechanical stop, and continue to work although calibration will be imprecise.	Reset fixture. Contact Martin service personnel if problem continues.
<i>CYER</i> (Cyan time-out) <i>MAER</i> (Magenta time-out) <i>YEER</i> (Yellow time-out)	...there is a malfunction in the electric indexing circuit for one of the CMY filters.	Reset fixture. Contact Martin service personnel if problem continues.
<i>HTCO</i> (Head temperature cutout)	...the head temperature is above maximum.	Ensure free airflow around air vents. Clean fixture as described in manual. Check that ambient temperature does not exceed max. permitted level. Contact Martin service personnel for assistance.
<i>DRER</i>	...one or more motor drivers fail.	Contact Martin service personnel for assistance.
<i>RCER</i>	... the real time clock is not running correctly.	Contact Martin service personnel for assistance.
<i>OPER</i>	...there is an onboard programming error.	Contact Martin service personnel for assistance.
<i>DPER</i>	...there is a display programming error.	Contact Martin service personnel for assistance.
<i>DIER</i>	...there is an internal dimmer error.	Contact Martin service personnel for assistance.
<i>DIPE</i>	...there is a problem updating the internal dimmer firmware.	Contact Martin service personnel for assistance.
<i>LAEX</i>	...the fixture has entered lamp explosion mode because it has detected a lamp failure. Pan and tilt are locked and DMX control is disabled.	Check lamp. Pan and tilt are released and DMX control is re-enabled when power is reapplied.
<i>F1ER</i>	...there is a base fan error.	Contact Martin service personnel for assistance.
<i>F2ER</i>	...there is a lamp fan error.	Contact Martin service personnel for assistance.
<i>F3ER</i>	...there is a head fan error.	Contact Martin service personnel for assistance.

Table 6: Display messages

Troubleshooting

Problem	Probable cause(s)	Remedy
Fixture is completely dead.	No power to fixture.	Check power and connections.
	Fuse blown (located on PCBs behind connections panel).	Isolate fixture from power. Check fuses and replace.
One or more fixtures resets correctly but responds erratically or not at all to the controller.	Bad data link.	Inspect connections and cables. Correct poor connections. Repair or replace damaged cables.
	Data link not terminated.	Insert termination plug in output jack of the last fixture on the link.
	Incorrect fixture DMX addressing.	Check addressing on fixture and controller. Check fixture is set to correct DMX mode.
	One of the fixtures is defective and is disturbing data transmission on the link.	Unplug XLR in and out connectors and connect them directly together to bypass one fixture at a time until normal operation is regained. Have faulty fixture serviced by Martin service technician.
	XLR pin-out on fixtures does not match (pins 2 and 3 reversed).	Install a phase-reversing cable between the fixtures or swap pins 2 and 3 in the fixture that behaves erratically.
Time-out error after fixture reset.	Effect requires mechanical adjustment.	Disable effects feedback (see page 19). Contact Martin for service.
Mechanical effect loses position.	Mechanical train requires cleaning, adjustment, or lubrication.	Contact Martin for service.
No light output.	Lamp faulty or burnt out	Disconnect fixture and replace lamp.
	External/internal dimmer switch set to External, but no lamp power from external dimmer system.	Switch to internal dimmer or check external dimmer system.
	Internal dimmer faulty (dimmer error message will appear in display).	Contact Martin for service.
	Lamp voltage rating too high for dimmer output voltage.	Install lamp with correct voltage rating.
Light output abnormally low.	Fixture set to reduced lamp power via economy mode.	Adjust setting in control menus.
	Lamp faulty or worn out.	Disconnect fixture and replace lamp.
	Lamp voltage rating too high for dimmer output voltage.	Install lamp with correct voltage rating.
Lamp lifetime less than one second.	Lamp voltage rating too low for dimmer output voltage.	Kick yourself, then install lamp with correct voltage rating. If there is now no light output from fixture, internal dimmer may be damaged. Kick yourself again and contact Martin for service.
Lamp cuts out intermittently.	Fixture is too hot.	Ensure free airflow around air vents. Clean fixture, especially fans, vents and filters. Check that ambient temperature does not exceed max. permitted level. Contact Martin for service.
Fans excessively noisy.	Fans set to full speed in control menu.	Adjust setting.
	Fixture is too hot.	Ensure free airflow around air vents. Clean fixture, especially fans, vents and filters. Check that ambient temperature does not exceed max. permitted level. Contact Martin for service.

Table 7: Troubleshooting

Circuit board connections

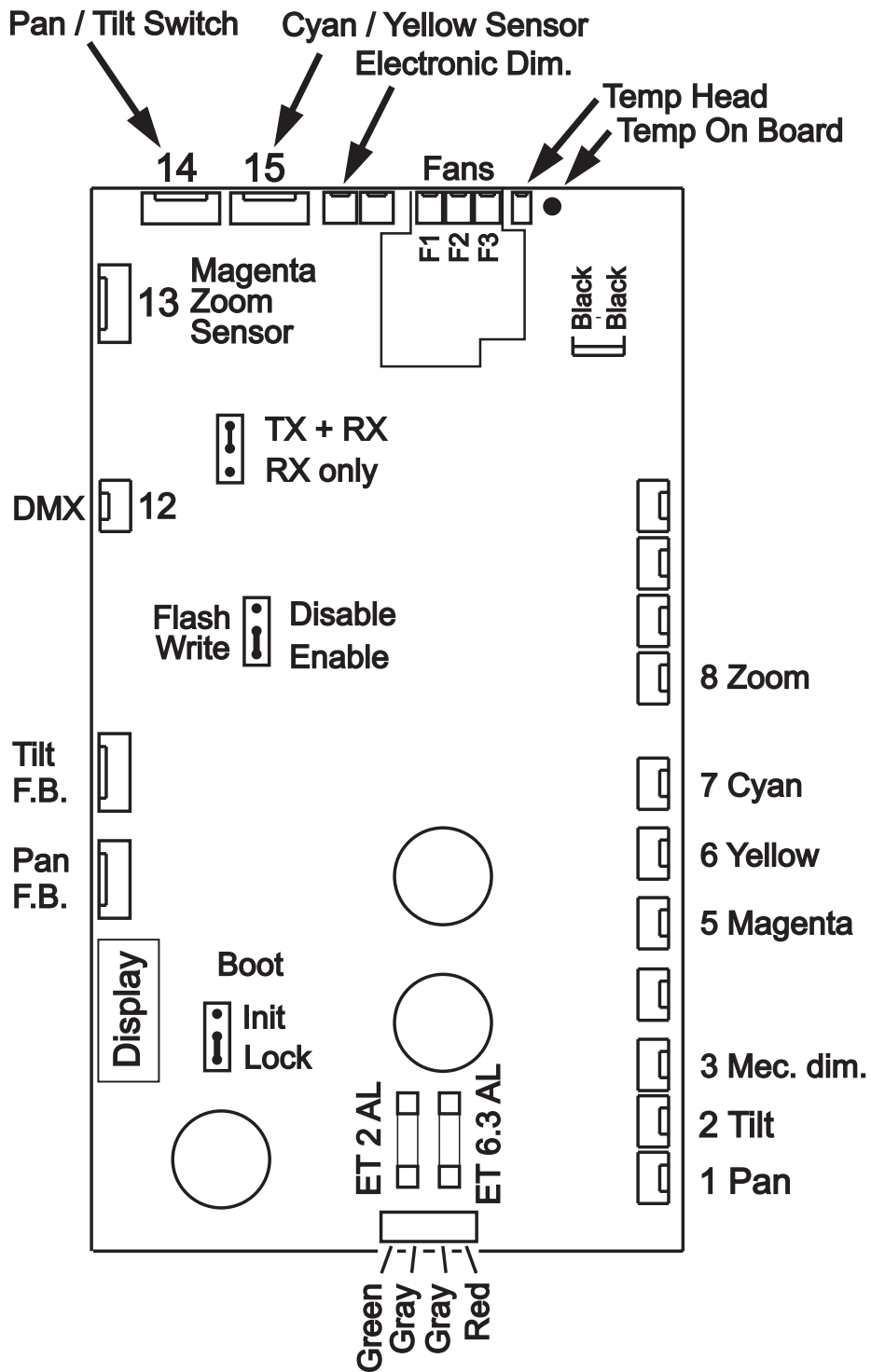

MAC TW1 specifications

PHYSICAL

Base length	454 mm (17.9 in.)
Base width	362 mm (14.3 in.)
Height, head straight up, no accessories mounted	709 mm (27.9 in.)
Height, head at maximum protrusion, no accessories mounted	735 mm (28.9 in.)
Weight, Multi-voltage IGBT Dimmer model	26.8 kg (59.1 lbs.)
Weight, 80 V Dimmer model	27.4 kg (60.4 lbs.)

LAMP

Type	1200 W tungsten-halogen
Base	PGJX-50
Approved models	Philips Hi-Brite 1200/80 FastFit 80 V
	Philips 1200/115 FastFit 115 V
	Philips 1200/230 FastFit 230 V
	Philips 1200/240 FastFit 240 V

DYNAMIC EFFECTS

Color mixing	CMY, independently variable 0 - 100%, 8- or 16-bit control
Electronic dimming	Full range via internal or external dimmer
Mechanical shutter	Full range dimming, strobe effect variable 2 to 10 Hz, 8- or 16-bit control
Zoom	20° - 41°, 8- or 16-bit control
Pan	540°, 16-bit control
Tilt	242°, 16-bit control
Position correction system	Yes

CONTROL AND PROGRAMMING

DMX channels	14 (16-bit basic mode) or 20 (16-bit extended mode)
Setting and addressing	Control panel with LED display or MP-2 uploader
Pan/tilt resolution	16-bit
CMY resolution	8- and 16-bit
Zoom resolution	8- and 16-bit
Movement control options	Tracking and vector
Protocol	USITT DMX 512-A
Receiver	Opto-isolated RS-485
Firmware update	Serial upload (MUF)

DIMMING SYSTEM OPTIONS

Internal multi-voltage IGBT dimmer	0 - 100%, 8- or 16-bit dimming resolution, controlled via DMX
Internal 80 V dimmer	0 - 100%, 8- or 16-bit dimming resolution, controlled via DMX
External dimmer input	Intelligent lamp power control

PHOTOMETRIC DATA

80 V lamp, standard lens

Total output (max.)	13 600 lm
One-tenth peak output (max.)	12 900 lm
Zoom range (one-tenth peak angles)	20° - 41°

115 V lamp, standard lens

Total output (max.)	10 900 lm
One-tenth peak output (max.)	10 400 lm
Zoom range (one-tenth peak angles)	19° - 40°

230 and 240 V lamps, standard lens

Total output (max.)	8900 lm
One-tenth peak output (max.)	8500 lm
Zoom range (one-tenth peak angles)	20° - 41°

Full photometric data and reports are available from <http://www.martin.com/service>

CONSTRUCTION

Color	Black
Housing	UV-resistant fiber-reinforced composite shell
Chassis	Steel and aluminum, shock-resistant design
Reflector	Glass, cold light
Handling	Ergonomic carrying handles
Protection factor	IP 20

INSTALLATION

Orientation	Any
Mounting points	2 pairs of 1/4-turn locks
Minimum distance from illuminated surface	0.5 m (20 in.)
Minimum distance from combustible materials	0.5 m (20 in.)
Minimum center-to-center distance, no accessories installed	550 mm (21.7 in.)

CONNECTIONS

AC power input	3 m (9.8 ft.) cable tail without plug
DMX data in/out	Locking 3-pin & 5-pin XLR, pin 1 shield, pin 2 cold (-), pin 3 hot (+)
External dimmer	Neutrik PowerCon®

ELECTRICAL

AC power	100-120/200-240 V nominal, 50/60 Hz
Power supply	Auto-ranging electronic switch-mode
Main fuse	20 AT (slow blow)

Typical power and current

115 V, 60 Hz	1226 W, 10.7 A, PF 0.998
230 V, 50 Hz	1220 W, 5.3 A, PF 0.995
240 V, 50 Hz	1233 W, 5.2 A, PF 0.996
230 V, 50 Hz using internal 80 V dimmer	1219 W, 5.5 A, PF 0.970
230 V, 50 Hz using external dimmer, figures for fixture only	93 W, 1.0 A, PF 0.420

PF = Power Factor.

Figures are valid at nominal voltage and are typical, not maximum. Allow for +/- 10% variation.

THERMAL

Lamp cooling	Patent-pending low noise ducted forced air system
Cooling	Filtered forced air (temperature-regulated, low noise)
Maximum ambient temperature (T_a max.)	40° C (104° F)
Minimum ambient temperature (T_a min.)	0° C (32° F)
Maximum surface temperature, steady state, $T_a = 40° C (104° F)$	200° C (392° F)
Total heat dissipation (calculated, 230 V, 50 Hz / 110 V, 60 Hz)	4160 / 4180 BTU/hr.

ACOUSTIC

Noise level < 40 dBA at 1 m (3.3 ft.), $T_a = 20° C (68° F)$, steady state, lamp on, effects static

APPROVALS



US safety	ANSI/UL 1573
Canadian safety	CSA C22.2 NO 166
EU safety	EN 60598-2-17
EU EMC	EN 55 015, EN 55 103-1, EN 61 547

INCLUDED ITEMS

Two 20 AT main fuses (installed)	2 x P/N 05020051
Two 20 AT external dimmer circuit fuses (installed)	2 x P/N 05020051
Two omega clamp attachment brackets with quarter-turn fasteners	2 x P/N 91602001

ACCESSORIES

Super wide angle lens kit	P/N 91610032
Front accessory holder	P/N 91611260
Internal 80 V dimmer	P/N 91614026
Flight case (holds 2 fixtures)	P/N 91510019
Half-coupler clamp	P/N 91602005
G-clamp	P/N 91602003
Quick trigger clamp	P/N 91602007
Omega bracket	P/N 91602001
Safety wire, universal, 50 kg safe work load	P/N 91604003
DMX cable, STP, 1 pair + shield, IEC/UL-CL, 1 m	P/N 91611242
DMX cable, STP, 1 pair + shield, IEC/UL-CL, 2 m	P/N 91611243
DMX cable, STP, 1 pair + shield, IEC/UL-CL, 5 m	P/N 91611244
DMX cable, STP, 1 pair + shield, IEC/UL-CL, 10 m	P/N 91611245
DMX cable, STP, 1 pair + shield, IEC/UL-CL, 20 m	P/N 91611246
Neutrik Powercon [®] cable connector for external dimmer cable	P/N 05342804
Narrow angle lens	Contact Martin for availability details
Gel frame	Contact Martin for availability details
Mesh frame	Contact Martin for availability details
Egg crate	Contact Martin for availability details
Concentric rings	Contact Martin for availability details
Top hat	Contact Martin for availability details
Barndoors	Contact Martin for availability details

RELATED ITEMS

MP-2 Uploader	P/N 90758420
DABS1 Hardware Interface (USB-XLR)	P/N 91611144

SPARE PARTS

Philips Hi-Brite 1200/80 FastFit 80 V lamp	P/N 97000006
Philips 1200/115 FastFit 115 V lamp	P/N 97000112
Philips 1200/230 FastFit 230 V lamp	P/N 97000113
Philips 1200/240 FastFit 240 V lamp	P/N 97000114

ORDERING INFORMATION

MAC TW1, Multi-voltage, IGBT dimmer, cardboard packing case	P/N 90202000
MAC TW1, Multi-voltage, IGBT dimmer, double flightcase	P/N 90202001
MAC TW1, Multi-voltage, 80 V dimmer, cardboard packing case	P/N 90202400
MAC TW1, Multi-voltage, 80 V dimmer, double flightcase	P/N 90202401

Specifications subject to change without notice.

Notes

Notes

Notes

