

Stagebar 54

user manual



Dimensions

All dimensions are in millimeters

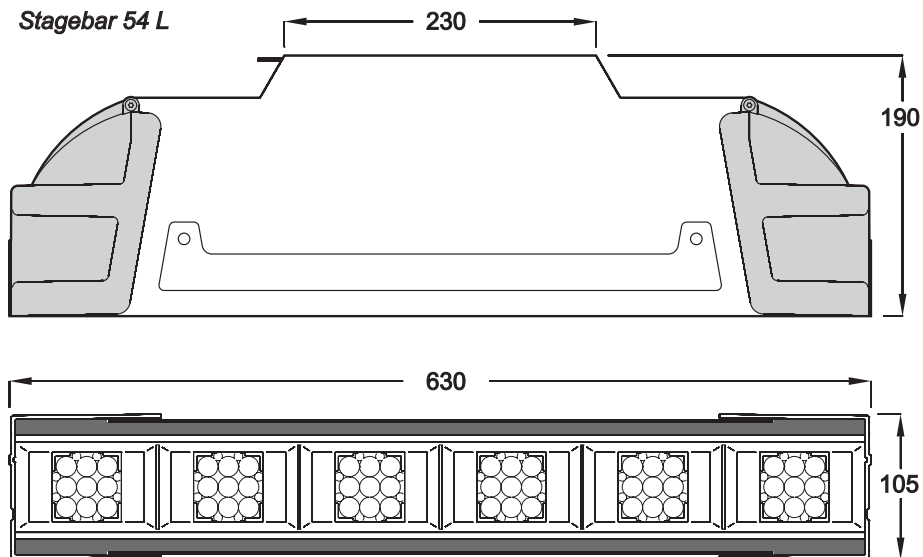
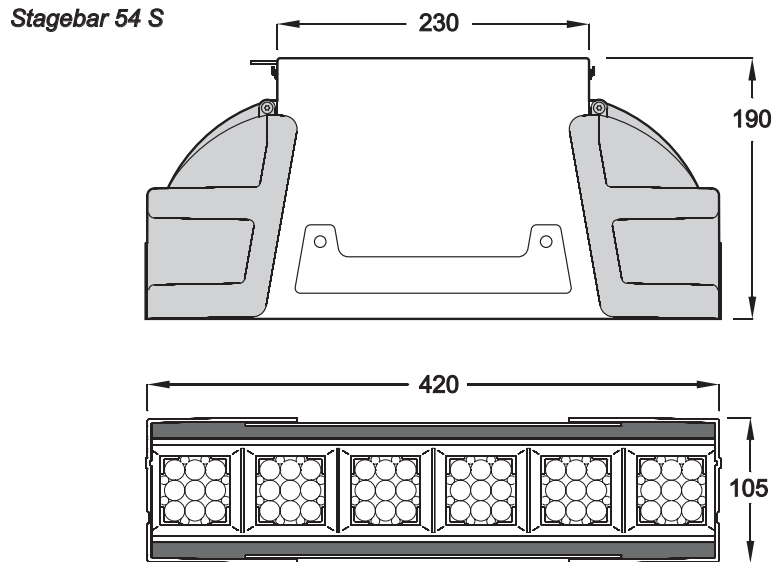

©2007 Martin Professional A/S, Denmark. All rights reserved. No part of this manual may be reproduced, in any form or by any means, without permission in writing from Martin Professional A/S. Information subject to change without notice. Martin Professional A/S and all affiliated companies disclaim liability for any injury, damage, direct or indirect loss, consequential or economic loss or any other loss occasioned by the use of, inability to use or reliance on the information contained in this manual. The use of certain patents in Martin Stagebar products is licensed by Color Kinetics®, Inc. (see details printed on product).

P/N 35000195, Rev. C

Safety Information



WARNING!

Read the safety precautions in this section before installing, powering, operating or servicing this product.

The following symbols are used to identify important safety information on the product and in this manual:



DANGER!
Safety hazard.
Risk of severe injury or death.



Warning!
LED light emission. Risk of eye injury.



Warning!
Refer to manual before installing, powering or servicing.



Warning!
Hazardous voltage. Risk of lethal or severe electric shock.



Warning!
Fire hazard.



Warning! Class 2M LED product. Do not look into the beam from a distance of less than 40 cm (16 inches). Do not stare into the beam for extended periods at a short distance. Do not view the beam directly with optical instruments.



This product is for professional use only. It is not for household use.

This product presents risks of severe injury or death due to fire hazards, electric shock and falls.



Read this manual before installing, powering or servicing the fixture, follow the safety precautions listed below and observe all warnings in this manual and printed on the fixture. If you have questions about how to operate the fixture safely, please contact your Martin dealer or call the Martin 24-hour service hotline at +45 70 200 201.



PROTECTION FROM ELECTRIC SHOCK

- Shut down power to the entire installation at the building's main power distribution board and lock out power (by removing the fuse for example) before carrying out any installation or maintenance work.
- Disconnect the fixture from AC power before removing or installing any cover or part and when not in use.
- Always ground (earth) the fixture electrically.
- Use only a source of AC power that complies with local building and electrical codes and has both overload and ground-fault (earth-fault) protection.
- Connect this fixture to AC power either using the supplied power cable or via 3-conductor cable that is rated minimum 20 amp, hard usage. Suitable cable types include ST, SJT, STW, SEO, SEOW and STO.
- The voltage and frequency at the power outlet are the same as the voltage and frequency applied to the power inlet. Only connect devices to the power outlet that accept this voltage and frequency.
- Before using the fixture, check that all power distribution equipment and cables are in perfect condition and rated for the current requirements of all connected devices.
- Do not use the fixture if the power cable or power plug are in any way damaged, defective or wet, or if they show signs of overheating.

- Do not expose the fixture to rain or moisture.
- Refer any service operation not described in this manual to a qualified technician.



PROTECTION FROM FIRE

- Do not attempt to bypass thermostatic switches or fuses. Replace defective fuses with ones of the specified type and rating only.
- Provide a minimum clearance of 0.1 m (4 in.) around fans and air vents.
- Do not modify the fixture or install other than genuine Martin parts.
- Do not stick filters, masks or other materials directly onto LEDs.
- Do not operate the fixture if the ambient temperature (T_a) exceeds 40° C (104° F).



PROTECTION FROM INJURY

- Do not hang fixtures from each other. Use one clamp per fixture when suspending.
- When suspending the fixture, ensure that the structure and all hardware used can hold at least 10 times the weight of all devices suspended from them.
- Use a secondary attachment (such as a safety cable) to secure each fixture. Secondary attachments must be able to hold at least 10 times the weight of all devices suspended from them and must be installed as described in this manual.
- Check that all external covers and rigging hardware are securely fastened.
- Block access below the work area and work from a stable platform whenever installing, servicing or moving the fixture.
- The LED emission presents a hazard to eyesight at a distance of 4 - 40 cm (1.6 - 16 inches) when the eye is exposed to the beam for longer than 0.25 seconds.
- Do not look at LEDs from a distance of less than 40 cm (1 ft. 4 in.) without suitable protective eyewear.
- Do not look at LEDs with magnifiers or similar optical instruments that may concentrate the light output.



Disposing of this product

Martin® products are supplied in compliance with Directive 2002/96/EC of the European Parliament and of the Council of the European Union on WEEE (Waste Electrical and Electronic Equipment), as amended by Directive 2003/108/EC, where applicable.

Help preserve the environment! Ensure that this product is recycled at the end of its life. Your supplier can give details of local arrangements for the disposal of Martin products.

Contents

Dimensions	2
Safety Information.....	3
Product overview.....	6
Introduction	7
Unpacking	7
Using for the first time	7
Physical installation	8
Adjustable mounting bracket	8
Standing installation.....	8
Flying from a truss, bar or other structure	8
AC power	9
Power connection	9
Relaying power to other devices	9
Control data link.....	11
Connection pinouts	11
Fixture setup.....	12
DMX addresses and DMX mode	12
Fixture settings	13
Fixture readouts.....	13
Other utilities	13
Service and maintenance.....	14
Cleaning.....	14
Removing and installing LED lenses.....	15
Installing and removing the diffuser front.....	16
Fuse replacement	16
Battery service	17
Reflector removal.....	17
Software installation.....	17
DMX protocols	18
RGB Mode.....	18
RGBAW Mode	18
HSI Mode.....	18
HSIC Mode	19
Onboard control panel menus.....	20
Display messages.....	21
Troubleshooting	22
Stagebar 54 specifications.....	23

Product overview

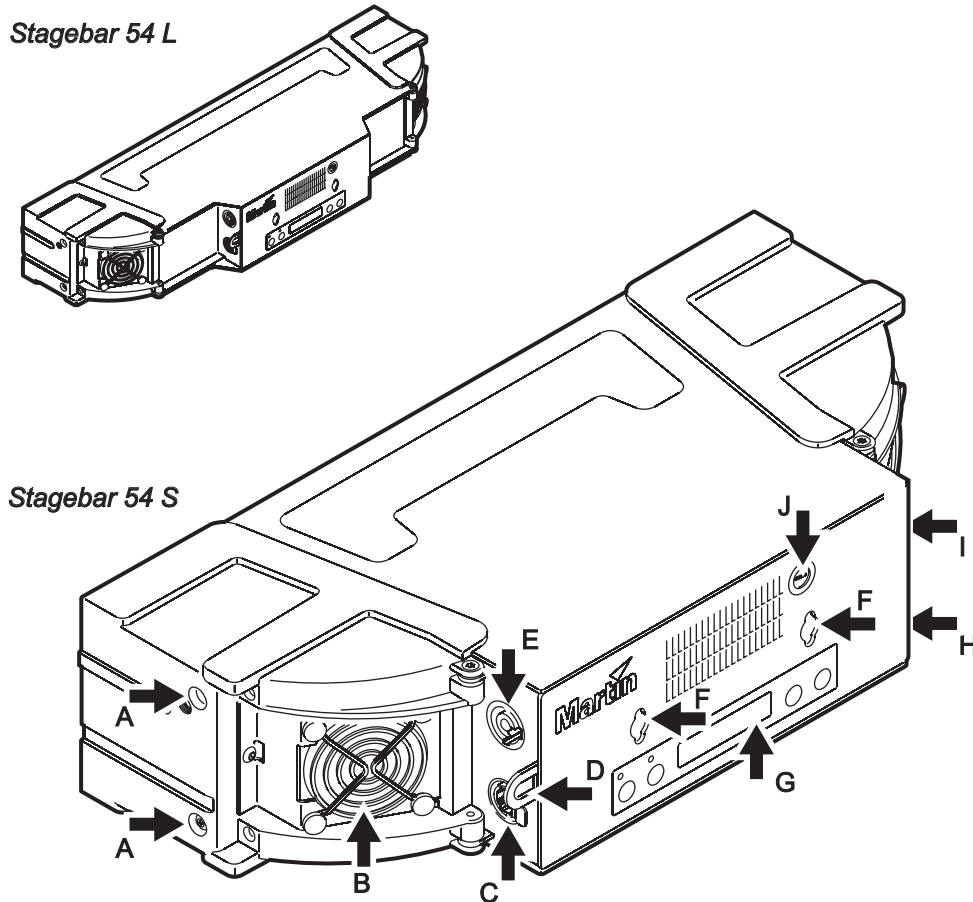

A - End cap release screws

B - Cooling fan

C - Data input connector (RJ-45)

Connect to DMX control data from the controller or previous fixture.

D - Safety attachment eye

Use only this attachment point for secondary attachment (e.g. safety cable).

E - Power inlet (PowerCon blue)

Connect a power cable with a blue Neutrik® PowerCon® connector from a 100-240 VAC nominal 50/60 Hz power source.

F - Quarter-turn mounting points

Use to attach the floorstand/mounting bracket supplied with the fixture or an omega bracket.

G - Control panel/display

H - Data output connector (RJ-45)

Use to relay DMX control data to the next fixture.

I - Power outlet (PowerCon light grey)

Connect a power cable with a light-grey Neutrik® PowerCon® connector to lead power to the next fixture. The total current draw of all the devices connected to the power outlet of the first fixture in the chain must not exceed 15 amps peak, 11 amps constant

J - Primary fuseholder

Replace fuse with one of same type and rating only.

Figure 1: Connections panel

Introduction

Thank you for selecting the Stagebar 54, a modular LED-based color changer and pixel display fixture from Martin. This product features:

- Luxeon K2 high-power LEDs
- 116 watts total LED output per fixture at 25° C (77° F)
- RGBAW (red, green, blue, amber, white), and RGB color mixing, HSIC (hue, saturation, intensity, color temperature) and HSI color management
- 54 LEDs arranged into 6 pixels per fixture
- Individual (6 x 1) or grouped (1 x 6, 2 x 3 or 3 x 2) pixel control
- Diffuser front for even color rendition
- 25° viewing angle
- DMX 512A control (3 - 30 channels depending on control mode)
- Control data in/out via RJ-45 connectors
- Control panel and full text backlit LCD display with battery power for offline setting and addressing
- Auto-sensing power supply unit with 100 - 240 V, 50/60 Hz operating range
- Daisy-chainable power link
- Power in/out via Neutrik® PowerCon® connectors
- Adjustable floorstand/mounting bracket
- Quarter-turn fastener mounting points
- Short (Stagebar 54S) and long (Stagebar 54L) models. To simplify the combination of different models in installations, three short models have the same length as two long models.

For the latest firmware updates, documentation, and other information about this and all Martin Professional products, please visit the Martin website at <http://www.martin.com>

Comments or suggestions regarding this document may be e-mailed to service@martin.dk or posted to:

Service Department
Martin Professional A/S
Olof Palmes Allé 18
DK-8200 Aarhus N
Denmark

Unpacking

The following items are included with the Stagebar 54:

- 3 m power cable with blue Neutrik® PowerCon® power input connector
- 5-pin XLR to RJ-45 adapter
- Adjustable floorstand/mounting bracket
- Six 3 x 3 LED lens sheets (installed)
- Diffuser front
- This user manual

Using for the first time

Before applying power to the fixture:

- Carefully review “Safety Information” on page 3.
- Check that the local AC power voltage is within the ranges listed on the serial number label and in “AC power” on page 9.
- Install a power plug on the power cable as described in “Power connection” on page 9.

Physical installation



WARNING! Use either the supplied adjustable floorstand/mounting bracket or an omega bracket and rigging clamp to install each Stagebar 54. With all methods of installation:

1. Check that all structures, equipment or surfaces used for support can bear at least 10 times the weight of all the fixtures, clamps, cables, auxiliary equipment, etc. that they will support.
2. Check that there are no combustible materials within 0.5 m (20 in.) of the fixtures when installed, and that there are no flammable materials nearby.
3. Do not hang fixtures from each other – every fixture must be installed with its own bracket and/or clamp.
4. Secure each fixture with an approved safety cable that can hold at least 10 times the weight of the fixture and hardware attached to it, looping the cable through the attachment point labelled on the fixture and over or through the supporting structure. Do not use the mounting bracket as a secondary attachment point, as this will leave the fixture unsecured.
5. If the diffuser front is not installed, make sure that it is impossible for LEDs to be viewed from a distance of less than 40 cm (16 inches).



If the diffuser front is installed, there is no eye hazard at any distance.

important! Make sure that there will be at least 0.1 m (4 in.) of free space and unrestricted airflow to and around the air vents in the back of the fixtures.

The Stagebar 54 can be installed in a standing position or suspended in any orientation from a truss or supporting structure. The supplied mounting bracket can be fitted with a rigging clamp or bolted to a surface. Alternatively, the mounting bracket can be replaced with an omega bracket and rigging clamp.

Adjustable mounting bracket

The adjustable mounting bracket supplied with the fixture can either be folded around the fixture and used as a floorstand, fastened directly to a surface or fitted with a rigging clamp for flying installation. Use at least two bolts, grade 8.8 minimum, if fastening to a surface. A drilling template is provided on the inside back cover of this manual.

Standing installation

If you install fixtures in a standing position:

1. Install fixtures on a level, stable surface where they do not present a hazard of tripping or falling.
2. Stack a maximum of four fixtures vertically and secure stacked fixtures so that they cannot fall over.

Flying from a truss, bar or other structure

To fly a fixture from a rig or other structure:

1. Install a rigging clamp on an omega clamp attachment bracket, then fasten the omega bracket to the fixture using the quarter-turn mounting points on the rear panel (see Figure 1 on page 6). Ensure that quarter-turn fasteners are turned a full 90° clockwise to lock them (see Figure 2).
2. Block access under the work area. Working from a stable platform, suspend the fixture by fastening the rigging clamp to the truss or structure. As soon as a fixture is fastened in place, install a secondary attachment such as a safety cable to secure it.

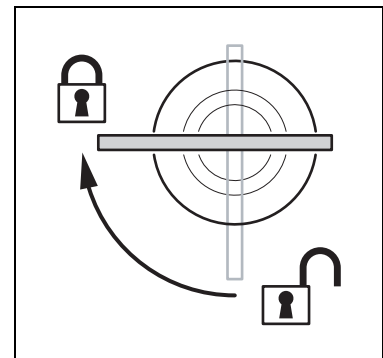

Figure 2: Locking a quarter-turn fastener

AC power



DANGER! Read “Safety Information” on page 3 before connecting the Stagebar 54 to AC power. Lock out power to the entire distribution system before carrying out installation work.

DANGER! Replace fuses with ones of the same type and rating only.



Important! Do not supply the fixture with power via an external dimming system, or you may cause damage the fixture that is not covered by the product warranty.

The Stagebar 54 features an auto-sensing switch-mode power supply that automatically adapts to 100 - 240 V nominal AC power at 50 or 60 Hz. Only connect the fixture to AC power within this voltage range.



Fixtures are protected by a 3.15 amp slow-blow primary fuse located in a fuseholder on the rear panel (see Figure 1 on page 6). The power output circuit is protected by a 15 amp slow-blow fuse located inside the fixture. See “Fuse replacement” on page 16 for details of changing fuses.

Power connection



DANGER! For protection from electric shock, the fixture must be grounded (earthed). Power distribution circuits must be fitted with a fuse or circuit breaker and ground-fault (earth-fault) protection.



Power is supplied to the fixture via a blue Neutrik® PowerCon® inlet that accepts a blue PowerCon® NAC3FCA cable connector. Power can be relayed to another device via the light-grey PowerCon® outlet that accepts a light-grey PowerCon® NAC3FCB cable connector. Note that blue input and light-grey output connectors have different designs: one type cannot be connected to the other.

You may need to fit the power cable with a power plug that is suitable for your AC power outlets. If so, install a grounding-type (earthed) plug that is rated 20 A minimum. Follow the plug manufacturer's instructions. Table 1 shows some possible pin identification schemes; if pins are not clearly identified, or if you have any doubts about proper installation, consult a qualified electrician.

Wire Color	Pin	Symbol	Screw (US)
brown	live	L	yellow or brass
blue	neutral	N	silver
yellow/green	ground (earth)		green

Table 1: Power plug connections

There is no separate power on/off switch: power is applied to the fixture as soon as it is connected to power.

Relaying power to other devices

Important! To avoid blowing the power output fuse, the total current draw of all devices connected to one fixture's power outlet must not exceed 15 amps peak, 11 amps constant.

Fixtures can be linked in a chain, power outlet to power inlet, so that they all draw power via the first fixture, but certain points must be respected:

- Either the supplied power cable or a three-conductor cable rated SJT, 20 A minimum (12 AWG or 2.5 mm²) must be used to connect the first fixture to AC power.
- Either the supplied power cable or a cable rated SJT, 15 A minimum (AWG 14 or 1.5 mm²) must be used to connect the subsequent fixtures in the chain to the first fixture.

- The total current draw of all the fixtures in the chain after the first fixture must not exceed 15 amps peak, 11 amps constant. See the following examples for an explanation of what this means in practice:
 - At **100 V AC** power, a **maximum of five Stagebar 54 fixtures** may be linked in one chain so that they draw AC power from the same source. As stated in the Stagebar 54 Specifications (see page 23), each fixture draws a current of 2.5 A at 100 V. The first fixture will draw a current of 2.5 A. The four fixtures linked to the first fixture will draw a total of 10 A, which is within the 11 A limit for constant current draw.
 - At **230 V AC** power, a **maximum of 11 Stagebar 54 fixtures** may be linked in one chain so that they draw AC power from the same source. As stated in the Stagebar 54 Specifications (see page 23), each fixture draws a current of 1.1 A at 230 V. The first fixture will draw a current of 1.1 A. The ten fixtures linked to the first fixture will draw a total of 11 A, which is equal to the 11 A limit for constant current draw.

Control data link

The Stagebar 54 accepts a DMX 512A signal. Each fixture has two RJ-45 connectors on the connections panel: one for data input and one for data output. An RJ-45 to XLR converter cable is supplied with the fixture, allowing you to connect a standard DMX cable with XLR connectors.

Connection pinouts

XLR connection

XLR connectors are suitable if DMX cable is used for the data link. XLR pin numbers are normally marked on connectors. Connectors must be wired using the standard XLR DMX pin-out:

- Pin 1: Cable shield
- Pin 2: DMX Data 1 - (cold)
- Pin 3: DMX Data 1 + (hot)

Pins 4 and 5 on 5-pin XLR connectors are available for Data 2 connections in DMX 512-A or similar systems. They must be wired as follows:

- Pin 4: DMX Data 2 - (cold)
- Pin 5: DMX Data 2 + (hot)

To avoid ground/earth loop interference, ensure that the DMX cable shield does not come into contact with the shell or body of XLR connectors.

RJ-45 connection

Important! Do not connect the Stagebar 54's RJ-45 connectors to an Ethernet network.

RJ-45 connectors are suitable if CAT 5 cable is used for the DMX data link (CAT 5 cable is suitable for fixed installations only). RJ-45 cable connector pins are numbered from the left, looking at the face of the connector with the locking clip on top (see Figure 3). Connectors must be wired using the standard RJ-45 DMX pin-out:

- Pin 1 (WHITE/orange): DMX hot (+)
- Pin 2 (ORANGE/white): DMX cold (-)
- Pins 7 (WHITE/brown) and 8 (BROWN/white): Common

Pins 3 and 6 are available for Data 2 connections in DMX 512-A or similar systems. They must be wired as follows:

- Pin 3 (WHITE/green): Available for Data 2 hot (+)
- Pin 6 (GREEN/white): Available for Data 2 cold (-)

Pins 4 and 5 are not used in currently available lighting control systems but can be wired as follows:

- Pin 4 (BLUE/white)
- Pin 5 (WHITE/blue)

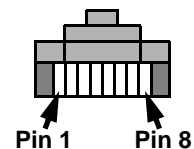

Figure 3: RJ-45 cable connector pins

Connecting the data link

To build a data link:

1. Cut power to all devices. If the luminaire has been in use, allow it to cool for at least 10 minutes.
2. Connect a DMX cable to the DMX output socket on the DMX controller and route it to the first luminaire on the link.
3. Connect the cable to the first fixture's DMX input socket, using an XLR to RJ-45 converter cable if necessary.
4. Continue adding fixtures, connecting DMX output to DMX input sockets.
5. When you have made all connections, set up the fixtures as described in the next section of this manual before applying power.

Fixture setup

The control panel and backlit LCD display on the Stagebar 54's rear panel allows you to set DMX addresses and alter various fixture settings. The Stagebar 54's onboard battery makes the most important fixture setup functions – including DMX addressing – available when the fixture is not connected to AC power.

- Press **Menu** to access the menu or go up one level.
- Press **Enter** to confirm a selection.
- Press **Up** and **Down** to navigate in the menus.

The current menu level is displayed in capital letters and sub-menus or menu items are displayed in small letters in the LCD display.

See “Onboard control panel menus” on page 20 for an overview of the menus available in the control panel.

DMX addresses and DMX mode

DMX mode

The **DMX mode** menu allows you to set the fixture to respond in one of four DMX control modes:

- **RGBAW** (red, green, blue, amber, white)
- **RGB** (red, green, blue)
- **HSIC** (hue, saturation, intensity, color temperature)
- **HSI** (hue, saturation, intensity)

The **DMX mode** menu also allows you to set up pixel control (one pixel is one of the six blocks of 9 LEDs in a Stagebar 54). You can control each pixel individually, so that each pixel displays its own color and is controlled using its own DMX channels, or you can control pixels in groups. Pixels in a group use the same DMX channels and behave identically. The options available are:

- **1** (each pixel is controlled individually)
- **2** (pixels are controlled in pairs, giving three groups of 2 pixels)
- **3** (pixels are controlled in two groups of 3 pixels)
- **All** (all pixels are controlled together in one group)

Deciding on DMX addresses

Depending on the DMX mode and pixel control setting selected in the control menus, each fixture uses the number of DMX channels shown in the table below. For example, a fixture in DMX mode **HSI**, with pixel control set to **3** (in which pixels are controlled in two groups of 3 pixels), will use six DMX channels. The first three channels will control hue, saturation and intensity on the first 3 pixels as a group, and the next three channels will control HSI on the remaining 3 pixels as a group.

Pixel control setting	RGB DMX mode	RGBAW DMX mode	HSI DMX mode	HSIC DMX mode
1 (individual control)	18	30	18	24
2 (three groups of 2 pixels)	9	15	9	12
3 (two groups of 3 pixels)	6	10	6	8
all (1 group of 6 pixels)	3	5	3	4

Table 2: DMX channels required in different control modes

Setting DMX addresses

The fixture's DMX address is set via the control panel.

Fixture settings

Besides the DMX address, various other fixture characteristics can be set using the control panel and display.

Adjustment

Gives manual control of the LED output for individual colors. This feature allows you to test LEDs or set a static color display without using a DMX controller.

Fixture readouts

Fixture info

Gives information about currently installed software version, total hours of use and temperature of the LED PCBs. The average temperature of all the PCBs or the temperature of the PCB that is currently the hottest can be displayed. Temperatures are given in degrees Celsius and Fahrenheit.

DMX link info

Gives information about the characteristics and quality of the DMX signal the fixture is receiving.

Other utilities

Test sequence

Runs a test sequence of all LEDs, fans, indicator LEDs and the LCD display.

Utilities

Prepares the fixture for an upload of new software and reloads the default factory settings.

The **UTILITIES** menu also contains **fan mode** settings that allows you to set the cooling fans to run in one of two modes:

- **regulated** (fans are thermostatically controlled, giving quietest operation)
- **full speed** (fans run at full speed while power is applied).

Service and maintenance



DANGER! Read “Safety Information” on page 3 before carrying out service or maintenance work on the Stagebar 54. Lock out power to the entire distribution system before servicing, cleaning or opening any cover. Refer any service operation not described here to a qualified service technician.

Important! Excessive dust, smoke fluid, and particle buildup degrades performance, causes overheating and will damage the fixture. Damage caused by inadequate cleaning or maintenance is not covered by the product warranty.

Important! As with electronic components in general, the Stagebar 54's PCBs are sensitive to ESD (electrostatic discharge). Take precautions to avoid ESD damage during service.

It is Martin policy to use the best quality materials available to ensure optimum performance and the longest possible component lifetimes. However, optical components in all lighting fixtures are subject to wear and tear over the life of the fixture, resulting in gradual changes in color rendition, for example.

The extent of wear and tear depends heavily on operating conditions, maintenance and environment, so it is impossible to specify precise lifetimes for optical components. However, you will eventually need to replace LEDs if their characteristics are affected by wear and tear after an extended period of use and if you require fixtures to perform within very precise optical and color parameters.

To maximize the life of the Stagebar 54 and protect the investment it represents, clean the fixture regularly – especially the cooling fans and grilles – following the guidelines in this section.

Cleaning

Regular cleaning is essential for fixture life and performance. Buildup of dust, dirt, smoke particles, fog fluid residues, etc. degrades the fixture's light output and cooling ability.

Cleaning schedules for lighting fixtures vary greatly depending on the operating environment. It is therefore impossible to specify precise cleaning intervals for the Stagebar 54. Cooling fans suck in airborne dust and smoke particles, and in extreme cases fixtures may require cleaning after surprisingly few hours of operation. Environmental factors that may result in a need for frequent cleaning include:

- Use of smoke or fog machines.
- High airflow rates (near air conditioning vents, for example).
- Presence of cigarette smoke.
- Airborne dust (from stage effects, building structures and fittings or the natural environment at outdoor events, for example).

If one or more of these factors is present, inspect fixtures within their first 25 hours of operation to see whether cleaning is necessary. Check again at frequent intervals. This procedure will allow you to assess cleaning requirements in your particular situation. If in doubt, consult your Martin dealer about a suitable maintenance schedule.

Do not use abrasive, caustic or solvent-based products for cleaning, as they can damage plastic or painted surfaces.

To clean the fixture:

1. Disconnect the fixture from power and allow it to cool for at least 10 minutes.
2. Vacuum or gently blow away dust and loose particles from the fan blades and grilles in the fixture's end caps with compressed air.
3. Clean the diffuser front with a soft cloth dampened in a warm water/detergent solution.
4. If the lens sheets require cleaning, remove their retaining screws and wash them in a hot water/detergent solution with a soft brush. Dry completely before reinstalling.



- See Figure 4. If a cooling fan or grille requires more thorough cleaning, loosen the fan assembly retaining screw (arrowed) slightly and slide the assembly out of the end cap for access. Do not strain the wires to the fan. Brush dirt from the fan blades with a soft brush, preferably in conjunction with a vacuum cleaner.

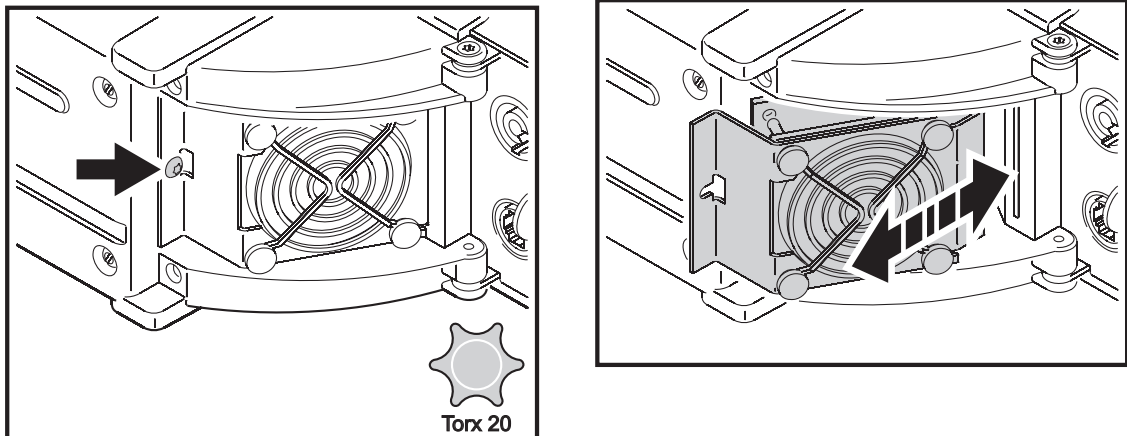

Figure 4: Cooling fan removal

- Avoid trapping wires while reinstalling the fan assembly.

Removing and installing LED lenses

The LED lenses are constructed in sheets of 9 lenses. The lenses concentrate the LED output into a 25° beam angle (half peak). Lenses must be removed to obtain smooth color using the diffuser front.

To remove a lens sheet:

- Isolate the fixture from power. If the fixture has been in use, allow it to cool for at least 10 minutes.
- See Figure 5. Remove the four retaining screws from the lens sheet and lift the lens sheet off its mounting pillars. Keep screws and lens sheets for future use.

To install a lens sheet:

- Isolate the fixture from power. If the fixture has been in use, allow it to cool for at least 10 minutes.
- Put the lens sheet into position and fasten it with the retaining screws.

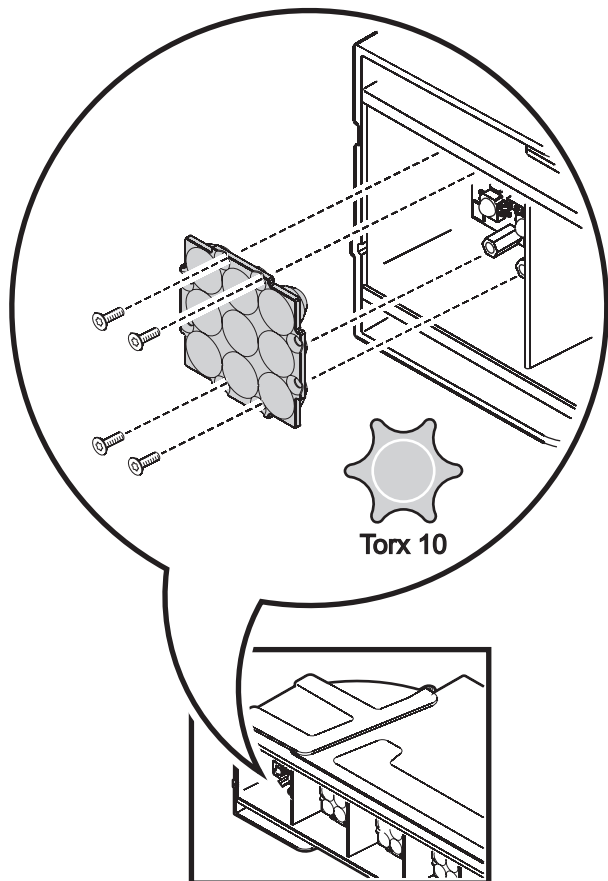

Figure 5: Lens removal

Installing and removing the diffuser front

The diffuser front makes the individual LEDs invisible, giving a surface with smooth color. Before installing it, remove the LED lenses as described on page 15, otherwise hot-spots will be visible on the diffuser surface.

To install a diffuser front:

1. Isolate the fixture from power. If the fixture has been in use, allow it to cool for at least 10 minutes.
2. See Figure 6. Loosen the two captive screws (arrowed) on the end cap and swing the end cap open.

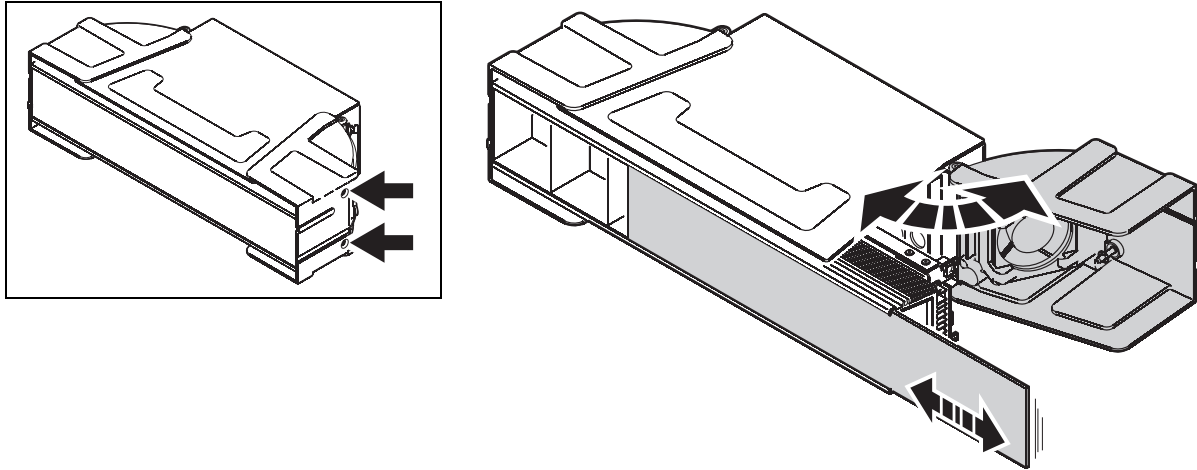

Figure 6: Installing / removing the diffuser front

3. Slide the diffuser front into the slots provided in the front of the fixture.
4. Close and fasten the end cap before reapplying power.

To remove a diffuser front:

1. Isolate the fixture from power. If the fixture has been in use, allow it to cool for at least 10 minutes.
2. See Figure 6. Loosen the two captive screws (arrowed) on the end cap and swing the end cap open.
3. Slide the diffuser front out of the slots in the front of the fixture.
4. Reinstall the LED lens sheets as described on page 15.
5. Close and fasten the end cap before reapplying power.

Fuse replacement



DANGER! Disconnect from power before opening covers. Replace fuses with ones of the same type and rating only.

Primary fuse



Stagebar 54 fixtures are protected by a 3.15 amp slow-blow primary fuse located in a fuseholder on the rear panel (see Figure 1 on page 6). If a fixture is completely dead (apart from the battery-powered functions available in the control panel and display), the primary fuse may have blown.

To replace the primary fuse:

1. Disconnect the fixture from power and allow to cool for 10 minutes.
2. Using a flat-head screwdriver, turn the fuseholder cap counter-clockwise to release it, then remove the fuse.
3. Replace a defective fuse with one of the same type and rating only. Replacement primary fuses are available from Martin suppliers (P/N 05020013).
4. Reinstall the fuseholder before reapplying power.

Power output fuse

The power output circuit and connector are protected by a 15 amp slow-blow fuse located inside the fixture on the mains filter PCB. If devices connected to a Stagebar 54 via the power output connector are dead but the Stagebar 54 is working normally, this fuse may have blown.

To replace the power output fuse:

1. Disconnect the fixture from power and allow to cool for 10 minutes.

2. Remove the blue power input connector from the power inlet. See Figure 6. Loosen the two captive screws (arrowed) on the end cap next to the power inlet and swing the end cap open.
3. The fuse is visible on the mains filter PCB. Remove it with long-nosed pliers, being careful not to disturb the power wiring.
4. Replace a defective fuse with one of the same type and rating only. Replacement primary fuses are available from Martin suppliers (P/N 05020050).
5. Reinstall the end cap before reapplying power.

Battery service

The onboard battery that provides power to the control panel and LCD display is recharged while the fixture is connected to AC power. If the battery has lost its charge over a long period with the fixture disconnected from AC power, the first remedy is to reconnect the fixture to power.

Due to natural aging, the battery will over time lose its ability to hold a charge. Eventually it will reach the end of its service life and require replacement. The battery is located immediately behind the bottom cover, attached to the chassis. Contact a Martin service technician for replacement.

Reflector removal

To remove the reflector, open both end caps as shown in Figure 6 on page 16 and lift the reflector out of the fixture.

Software installation

It may be necessary to upload new software to the Stagebar 54 if you believe that the product has a software-related fault or if you want to update to a newer version. Software updates are available from the Martin website (<http://www.martin.com>) and can be installed via the DMX data link with the following items:

- The Stagebar 54 main CPU software update file, downloadable free of charge from the Support area of the Martin website.
- The Martin Software Uploader program, version 5.0 or later, downloadable free of charge from the Support area of the Martin website.
- A Martin Universal USB-DMX Interface or similar PC/fixture hardware interface and Windows PC (or a Martin MP-2 Uploader device loaded with the Stagebar 54 main CPU software update file).

Installing software: normal method

1. Connect the uploader hardware to a Stagebar 54 fixture's data input connector. The software will be uploaded to that fixture and all Stagebar 54 fixtures that are powered on and connected via the DMX link.
2. Upload the fixture software as described in the uploader's help file or user documentation.
3. Disconnect the uploader hardware and reconnect the fixture to the DMX link.
4. Cycle power off and on. Check that the fixture resets correctly. If an error message appears in the display, cycle power off and on again and check that the fixture now resets correctly.

Installing software: boot mode upload

A boot mode upload must be carried out by a qualified professional only. If you believe that a boot mode upload may be required (if the display is completely dead when power is applied, for example), or if the software notes call for a boot mode upload:

1. Isolate the fixture from power and open for access to the main PCB.
2. Locate the DIP switch on the main PCB and move pin 6 to ON.
3. Close all covers, reapply power and perform the upload as described above.
4. Isolate from power, open covers, set DIP switch pin 6 to OFF, close all covers and reapply power.
5. Check that the fixture resets correctly. If a checksum error occurs, cycle power off and on again and check that the fixture now resets correctly.

DMX protocols

RGB Mode

Start code = 0

Channel	Value	Percent	Function
1	0 - 255	0 - 100%	Red Intensity 0 →100%
2	0 - 255	0 - 100%	Green Intensity 0 →100%
3	0 - 255	0 - 100%	Blue Intensity 0 →100%

RGBAW Mode

Start code = 0

Channel	Value	Percent	Function
1	0 - 255	0 - 100%	Red Intensity 0 →100%
2	0 - 255	0 - 100%	Green Intensity 0 →100%
3	0 - 255	0 - 100%	Blue Intensity 0 →100%
4	0 - 255	0 - 100%	Amber Intensity 0 →100%
5	0 - 255	0 - 100%	White Intensity 0 →100%

HSI Mode

Start code = 0

Channel	Value	Percent	Function
1	0 - 255	0 - 100	Hue Red → Orange → Amber → Yellow → Green → Cyan → Blue → Indigo → Violet → Magenta → Red
2	0 - 255	0 - 100	Saturation Zero (white) → Full
3	0 - 255	0 - 100%	Intensity Intensity 0 →100%

In HSI mode, white color temperature is fixed at 5500 K.

HSIC Mode

Start code = 0

Channel	Value	Percent	Function
1	0 - 255	0 - 100	Hue Red → Orange → Amber → Yellow → Green → Cyan → Blue → Indigo → Violet → Magenta → Red
2	0 - 255	0 - 100	Saturation Zero (white) → Full saturation
3	0 - 255	0 - 100%	Intensity Intensity 0 → 100%
4	0 - 255	0 - 100	Color Temperature Control 2000 - 10 000 K

A DMX value of 191 (75%) must be sent on channel 4 to obtain a white color temperature of 5500 K.

Onboard control panel menus

Menu	Options	Notes	
ADDRESS	1 - 510	Set the luminaire's DMX address	
DMX MODE	control mode	HSI	HSI DMX control
		HSIC	HSIC DMX control
		RGB	RGB DMX control
		RGBAW	RGBAW DMX control
	pixel grouping	1	Individual control of pixels
		2	Pixels controlled in 3 groups of 2 pixels
		3	Pixels controlled in 2 groups of 3 pixels
		all	Pixels controlled in 1 group of 6 pixels (control all pixels at same time)
ADJUSTMENT	red	Manually set red intensity	
	green	Manually set green intensity	
	blue	Manually set blue intensity	
	amber	Manually set amber intensity	
	white	Manually set white intensity	
PERSONALITY	backlight	intensity	Set display backlight intensity
		delay	Set time before display backlight goes into sleep mode
FIXTURE INFO	software version		Display main fixture software versions
	resettable hours		Display number of hours fixture powered on since last reset (to reset, display hours then press Up key for 5 secs.)
	total hours		Display number of hours fixture powered on since manufacture (non-resettable)
	temp. mainboard		Display main PCB temperature
	temp. driver	current	Display current average driver PCB temperature
		max since reset	Display highest driver PCB temperature since last fixture reset
		max recorded	Display highest driver PCB temperature since manufacture
	temp. pixel	current	Display current average pixel PCB temperature
		max since reset	Display highest pixel PCB temperature since last fixture reset
		max recorded	Display highest pixel PCB temperature since manufacture
DMX LINK INFO	refresh rate		Display DMX signal refresh rate
	link quality		Display DMX signal quality
	start code		Display DMX start code
	channel		Display DMX channel
TEST SEQUENCE	run		Test all components in sequence
UTILITIES (Hold Enter pressed in for 5 secs. to use this menu)	software upload		Set fixture to receive new software via DMX link
	factory setting		Return fixture to factory default settings
	fan mode	regulated	Set fans to thermostatically regulated operation
		full speed	Set fans to permanently on, full speed

All temperatures are displayed in °C and °F

Display messages

Message	Appears if...	What to do...
MERR	...there is an error communication with EEPROM memory	Contact Martin Service for assistance
F1ER F2ER	...there is a fan error on fan 1 or 2	Contact Martin Service for assistance
DTER	...there is a driver temperature sensor error	Contact Martin Service for assistance
PTER	...there is a pixel temperature sensor error	Contact Martin Service for assistance
FTCO	...the fixture temperature cutoff is activated	Clean fixture (especially fans and air vents), check that airflow around air vents is unobstructed, check ambient temperature. If this does not solve problem, contact Martin service for assistance.
D1C0 D2C0 D3C0 D4C0 D5C0 D6C0	...there is a temperature error on a driver PCB (1 - 6 identifies the PCB involved, C0 = Cutoff)	Contact Martin Service for assistance
P1C0 P2C0 P3C0 P4C0 P5C0 P6C0	...there is a temperature error on a pixel PCB (1 - 6 identifies the PCB involved, C0 = Cutoff)	Contact Martin Service for assistance
DPER	...there is a display programming error	Contact Martin Service for assistance
BALO	...the battery level is low	Apply power to fixture for several hours to recharge battery. If this does not solve problem, contact Martin Service for assistance.
DIER	...there is a display error	Contact Martin Service for assistance
DCER	...there is a driver board communication error	Contact Martin Service for assistance
RUER	...the fixture's unique I.D. (identification code) is missing from the fixture software or invalid	Contact Martin for assistance with obtaining and loading a new I.D.

Troubleshooting

Problem	Probable cause(s)	Remedy
Fixture is completely dead.	No power to fixture.	Check power and connections.
	Primary fuse blown (located in fuseholder on rear panel).	Isolate fixture from power. Check fuse and replace.
Fixture works normally but other fixtures connected to power output on rear panel are completely dead.	Power output fuse blown (located inside fixture behind right-hand end cap on PCB near power inlet).	Isolate fixture from power. Check fuse and replace.
One or more fixtures responds incorrectly to control or does not respond at all.	Fault on DMX link.	Inspect connections and cables. Correct poor connections. Repair or replace damaged cables.
	Incorrect fixture addressing.	Check fixture is set to correct DMX mode. Check number of channels required by fixture's DMX mode and check fixture addresses.
	Fixture defective.	Have faulty fixture serviced by Martin service technician.
	Other device on DMX link defective.	Bypass devices on DMX link until the faulty device has been identified. Have faulty device tested and serviced by Martin service technician or device supplier.
LEDs cut out intermittently.	Fixture is too hot.	Ensure free airflow around air vents. Clean fans and vents. Check that ambient temperature does not exceed maximum permitted level. Contact Martin for service.
LCD display dead when fixture is connected to power.	Fixture software is corrupted.	Contact Martin for assistance with boot mode software upload.
LCD display dead when fixture is not connected to power.	Onboard battery flat.	Connect to AC power to recharge battery.
	Battery defective or at end of service life.	Contact Martin for replacement.

Table 3: Troubleshooting

Stagebar 54 specifications

Physical

Stagebar 54S

Length	420 mm (16.5 in.)
Width	190 mm (7.5 in.)
Height	105 mm (4.1 in.)
Weight	5.5 kg (12.1 lbs.) without bracket

Stagebar 54L

Length	630 mm (24.8 in.)
Width	190 mm (7.5 in.)
Height	105 mm (4.1 in.)
Weight	7.3 kg (16.1 lbs.) without bracket

Dynamic Effects

Color mixing	RGBAW, RGB, HSI, HSIC, 0 - 100% independently variable
--------------	--

Control and Programming

DMX channels	3 - 30
Pixel control grouping options	6 x 1 (individual), 3 x 2, 2 x 3, 1 x 6 (all pixels as one group)
Setting and addressing	DMX, manual via onboard control panel and display
Display	Battery-powered backlit LCD, 2 x 16 character
Color calibration	Automatic correction system, software-assisted calibration package available as accessory
16-bit control (internal)	RGBAW, RGB, HSI, HSIC color mixing
Protocol	USITT DMX512-A
Receiver	RS-485
Firmware update	Serial upload via DMX link

Photometric Data

Light source	Luxeon K2 high power emitters
Half-peak beam angle	29°, consult Martin for availability of optional beam angles
Total LED power per pixel	2 x 1.2 W red, 2 x 2.9 W green, 2 x 2.9 W royal blue, 2 x 1.2 W amber, 1 x 2.9 W white
Total LED power per bar	116 W
Minimum total output	650 lm at 40° C (104° F) Ta
Even pitch across adjacent fixtures	Horizontal/vertical (Stagebar 54L), horizontal (Stagebar 54S)

Construction

Color	Black
Housing	Aluminum and steel
Finish	Electrostatic powder-coated
Protection rating	IP 20

Installation

Mounting points	Adjustable mounting bracket, 1/4-turn locks, four M6 threaded holes
Orientation	Any

Connections

Power in/out	Neutrik® Powercon®
Data in/out	RJ-45

Electrical

AC power	100 - 240 V nominal, 50/60 Hz
Power supply unit	Integrated, auto-sensing multi-voltage
Primary fuse	3.15 AT slow blow

Typical power and current

100 V, 50 Hz.	238 W, 2.5 A, PF 0.998
100 V, 60 Hz.	240 W, 2.5 A, PF 0.998
110 V, 60 Hz.	237 W, 2.3 A, PF 0.997
120 V, 60 Hz.	233 W, 2.1 A, PF 0.996
208 V, 60 Hz.	228 W, 1.2 A, PF 0.986
220 V, 50 Hz.	227 W, 1.1 A, PF 0.986
220 V, 60 Hz.	244 W, 1.3 A, PF 0.984
230 V, 50 Hz.	225 W, 1.1 A, PF 0.986
240 V, 50 Hz.	224 W, 1.0 A, PF 0.984

Figures apply to both S and L models with all LEDs at maximum intensity. Figures are valid at nominal voltage and represent typical averages, not maximum.

Thermal

Cooling.	Forced air
Maximum ambient temperature (Ta max.)	40° C (104° F)
Minimum ambient temperature (Ta min.)	5° C (41° F)
Maximum surface temperature, steady state, Ta=40° C	75° C (167° F)
Total heat dissipation (+/- 10%, calculated)	860 BTU/hr.

Acoustic

Noise level	<40 dBA at 1 m (3.3 ft.), steady state, Ta 25° C (77° F)
-----------------------	--

Approvals



EU safety	EN 60598-1, EN 60598-2-17, IEC/EN 60825-1
EU EMC.	EN 55 015, EN 55 103-1, EN 55 103-2
US safety (pending).	ANSI/UL 1573
Canadian safety (pending)	CAN/CSA E 60598-2-17

INCLUDED ITEMS

Diffuser front, 54S models	P/N 41704080
Diffuser front, 54L models	P/N 41704060
Adjustable floorstand/mounting bracket.	P/N 71606007
3 m power cable, 12 AWG, SJT, with PowerCon® NAC3FCA power input connector.	P/N 11541503
5-pin XLR male to RJ-45 adapter (both cable connectors Neutrik in locking housing)	P/N 11840114
User manual	P/N 35000195

Accessories

Neutrik® PowerCon® NAC3FCA power input connector, cable mount, blue.	P/N 05342804
Neutrik® PowerCon® NAC3FCB power output connector, cable mount, light grey.	P/N 05342805
PowerCon daisy-chain power cable, 1400 mm (55 in.)	P/N 11850099
PowerCon daisy-chain power cable, 2250 mm (88.5 in.)	P/N 11850100
PowerCon daisy-chain power cable, 3250 mm (128 in.)	P/N 11850101
RJ-45 patch cable, 250 mm (9.8 in.)	P/N 11840088
RJ-45 patch cable, 600 mm (23.5 in.)	P/N 11840105
5-pin XLR male to RJ-45 male adapter	P/N 11840114
5-pin XLR female to RJ-45 adapter	P/N 11840112
3-pin male XLR to male RJ-45 adapter	P/N 11840087
3-pin female XLR to male RJ-45 adapter.	P/N 11840086

XLR and RJ-45 connectors on adapter cables are both Neutrik®, in locking housing

Spare parts

3 m power cable, 12 AWG, SJT, with PowerCon® NAC3FCA power input connector.	P/N 11541503
Diffuser front, 54S models	P/N 41704080
Diffuser front, 54L models	P/N 41704060
Adjustable floorstand/mounting bracket.	P/N 71606007
15 AT power output fuse	P/N 05020050
3.15 AT primary fuse	P/N 05020013

Ordering Information

Stagebar 54S.	P/N 90352000
Stagebar 54L.	P/N 90352010

Specifications subject to change without notice.

Notes

Notes

Drilling template

