

ROBE

ROBIN[®] ParFect 100

ROBIN[®] ParFect 100
Wireless DMX

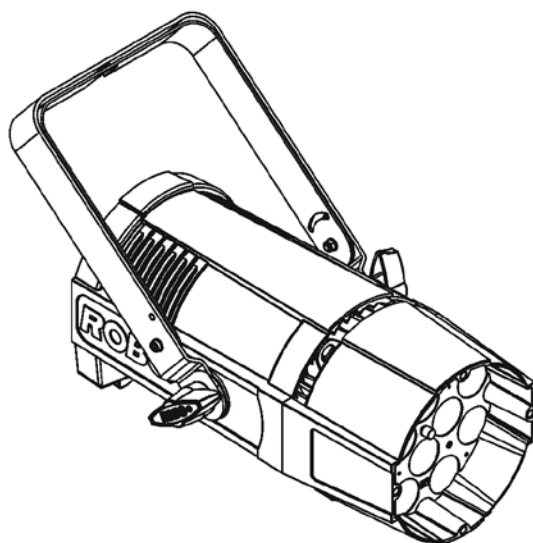

USER MANUAL

ROBE[®] lighting s.r.o. • Czech Republic • www.robe.cz

Version 1.0

Robin ParFect 100

Table of contents

1. Safety instructions	3
2. Fixture exterior view	5
3. Installation	6
3.1 Connection to the mains	6
3.2 Installing the diffusion filter	7
3.3 Installing barndoors and the gel frame	8
3.4 Rigging the fixture	10
3.5 DMX-512 connection.....	12
3.6. Wireless DMX operation	13
3.7. Stand-alone and Master/Slave operation	14
4. Control menu map	15
5. Robin ParFect 100 - DMX chart	17
5.1 Virtual colour wheel - colour mixing chart	20
5.2 LED zone order	24
6. Control menu	25
6.1 Addressing and master/slave setting (DMXA)	25
6.2 Fixture information (Info)	25
6.3 Personality (Pers).....	26
6.4 Manual Control (Manual).....	26
6.5 Test program (Test Prg).....	26
6.6 Stand-alone (St Alone)	27
6.7 Special functions (Special).....	27
7. RDM	29
8. Error and information messages	29
9. Technical Specifications	30
10. Maintenance and cleaning	32
11. Photometric diagrams	34

**FOR YOUR OWN SAFETY, PLEASE READ THIS USER MANUAL CAREFULLY
BEFORE POWERING OR INSTALLING YOUR ParFect 100 !**

Save it for future reference.

This device has left our premises in absolutely perfect condition. In order to maintain this condition and to ensure a safe operation, it is absolutely necessary for the user to follow the safety instructions and warning notes written in this manual.

The manufacturer will not accept liability for any resulting damages caused by the non-observance of this manual or any unauthorized modification to the device.

Please consider that damages caused by manual modifications to the device are not subject to warranty.

The ParFect 100 was designed for indoor use and it is intended for professional application only. It is not for household use.

1. Safety instructions

DANGEROUS VOLTAGE CONSTITUTING A RISK OF ELECTRIC SHOCK IS PRESENT WITHIN THIS UNIT!

Make sure that the available voltage is not higher than stated on the rear panel of the fixture. This fixture should be operated only from the type of power source indicated on the marking label. If you are not sure of the type of power supplied, consult your authorized distributor or local power company.

Always disconnect the fixture from AC power before cleaning, removing or installing the fuses, or any part.

The power plug has to be accessible after installing the fixture. Do not overload wall outlets and extension cords as this can result in fire or electric shock.

Do not allow anything to rest on the power cord. Do not locate this fixture where the cord may be damaged by persons walking on it.

Make sure that the power cord is never crimped or damaged by sharp edges. Check the fixture and the power cord from time to time.

Refer servicing to qualified service personnel.

This fixture falls under protection class I. Therefore this fixture has to be connected to a mains socket outlet with a protective earthing connection.

Do not connect this fixture to a dimmer pack.

LED light emission. Risk of eye injury. Do not look into the beam at a distance of less than 2 meters from the front surface of the product. Do not view the light output with optical instruments or any device that may concentrate the beam

If the fixture has been exposed to drastic temperature fluctuation (e.g. after transportation), do not switch it on immediately. The arising condensation water might damage your device. Leave the device switched off until it has reached room temperature.

Do not shake the fixture. Avoid brute force when installing or operating the fixture.

This fixture was designed for indoor use only, do not expose this unit to rain or use near water.

When choosing the installation spot, please make sure that the fixture is not exposed to extreme heat, moisture

or dust.

Air vents and slots in the fixture's head and base are provided for ventilation, to ensure reliable operation of the device and to protect it from overheating.

Do not block the LEDs array with any object when the fixture is under operation.

The openings should never be covered with cloth or other materials, and never must be blocked.

This fixture should not be placed in a built-in installation unless proper ventilation is provided.

Only operate the fixture after having checked that the housing is firmly closed and all screws are tightly fastened.

Always use a secondary safety cable when mounting this fixture.

Make sure that the area below the installation place is blocked when rigging, derigging or servicing the fixture.

Do not block the front objective LEDs with any object when the fixture is under operation.

The fixture becomes very hot during operation. Allow the fixture to cool approximately 20 minutes prior to manipulate with it.

Operate the fixture only after having familiarized with its functions. Do not permit operation by persons not qualified for operating the fixture. Most damages are the result of unprofessional operation!

Please use the original packaging if the fixture is to be transported.

Please consider that unauthorized modifications on the fixture are forbidden due to safety reasons!

If this device will be operated in any way different to the one described in this manual, the product may suffer damages and the guarantee becomes void. Furthermore, any other operation may lead to dangers like short-circuit, burns, electric shock, crash etc.

2. Fixture exterior view

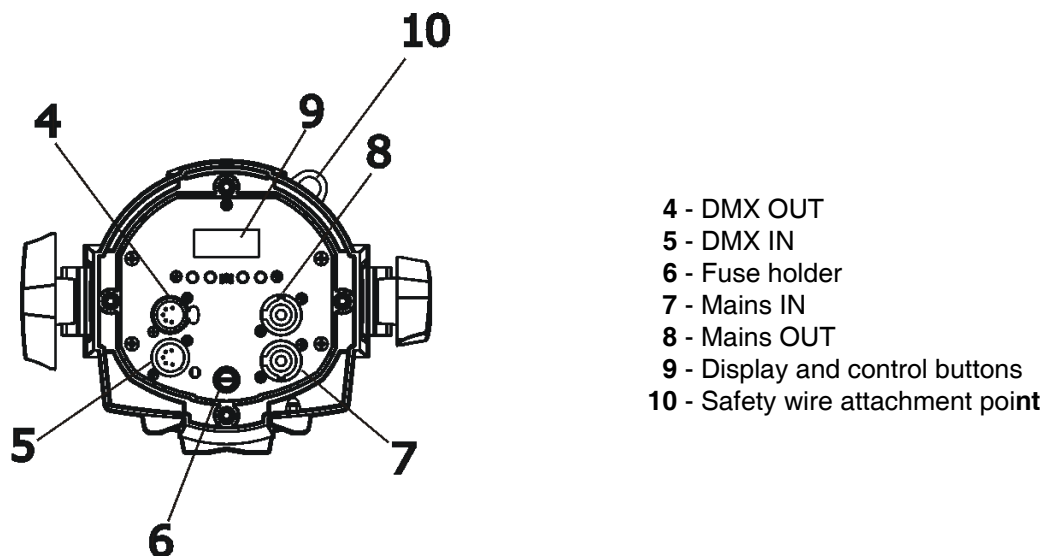
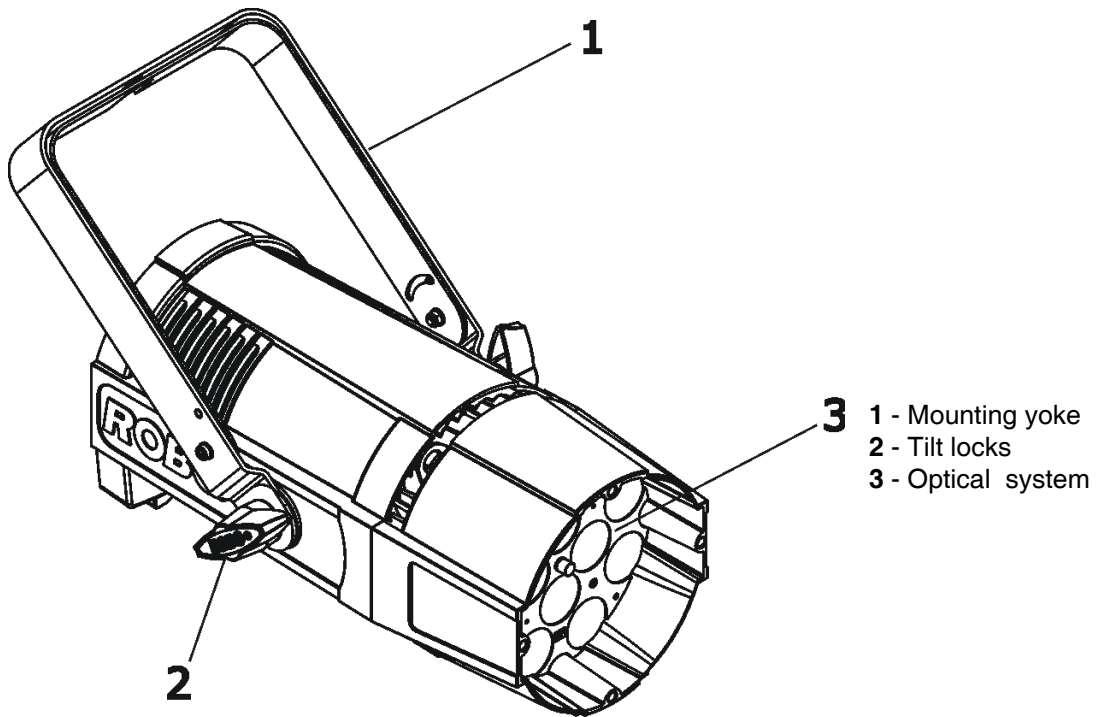

3. Installation



Fixtures must be installed by a Qualified electrician in accordance with all national and local electrical and construction codes and regulation.

3.1 Connection to the mains

For protection from electric shock, the fixture must be earthed!

The ParFect 100 is equipped with auto-switching power supply that automatically adjusts to any 50-60Hz AC power source from 100-240 Volts.

Install a suitable plug on the power cord, note that the cores in the power cord are coloured according to the following table. The earth has to be connected!

If you have any doubts about proper installation, consult a qualified electrician.

Core (EU)	Core (US)	Connection	Plug Terminal Marking
Brown	Black	Live	L
Light blue	White	Neutral	N
Yellow/Green	Green	Earth	

This device falls under class one and must be earthed (grounded)!

Design of the ParFect 100 allows to connect several fixtures to AC mains power in one interconnected daisy chain using power input and throughput connectors. Needed daisy chain cords are stated in the chapter "Technical specifications"

The max. number of connected fixtures depends on the AC mains power voltage:

12 fixtures at power supply= 230V

10 fixtures at power supply= 208V

6 fixtures at power supply= 120V

Do not overload the supply line and the connecting leads.

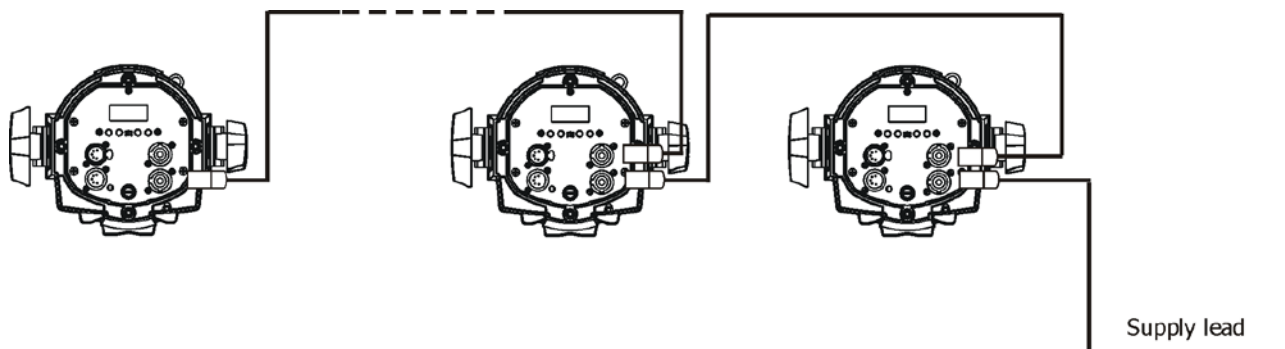

Wiring and connection work must be carried out by qualified staff!

3.2 Installing the diffusion filter

Disconnect the fixture from mains before diffusion filter installation

1. Disconnect the fixture from mains.

2. Insert the screw (1) with the plastic washer (2) into diffuser (3) and secure it by means of the plastic washer (4.)

2. Insert the diffuser (3) into the Perfect 100 and secure it by screwing the screw (1) into the thread hole (5) in the plastic eggcrate. Keep the correct orientation of the diffuser sections (6).

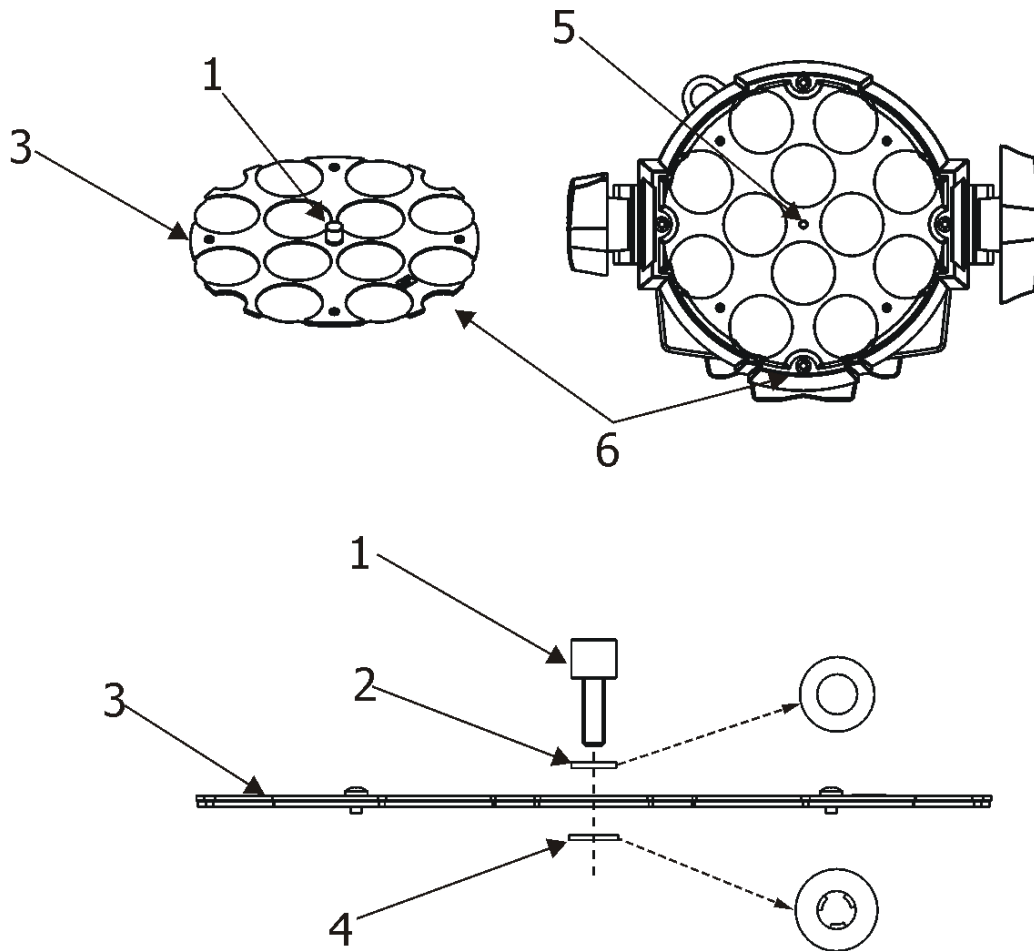

3.3 Installing barndoors and the gel frame

Disconnect the fixture from mains before barndoors and the gel frame installation

1. Disconnect the fixture from mains.

2. Screw the accessory frame adaptor (1) on the Perfect 100 housing with the four screws M4x8 (2) and unlock the spring lock (3) via pushing this spring lock as show red arrows on the picture.

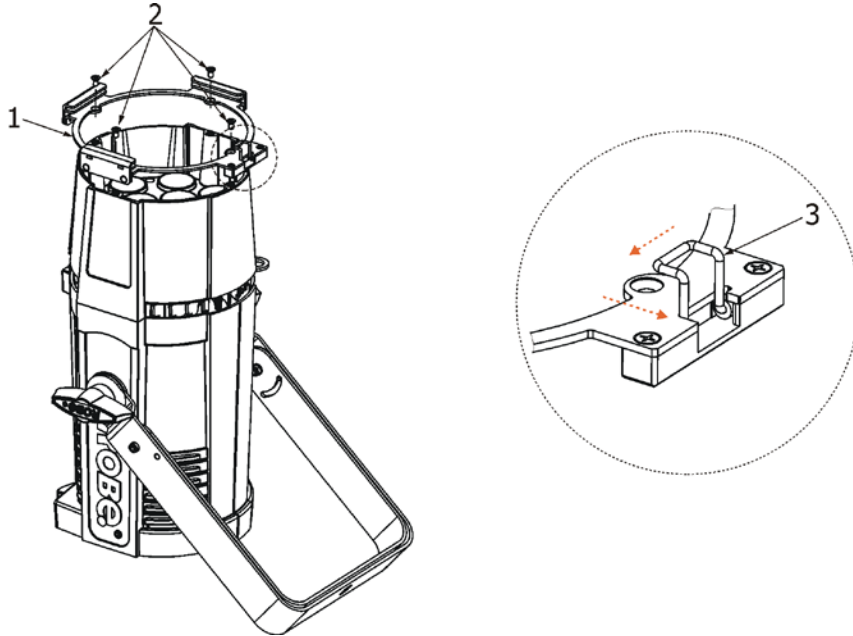

3. Insert the gel frame (4) into the bottom slots of the accessory frame adaptor (1).

4. Insert the barndoors (5) into the top slots of the accessory frame adaptor (1).

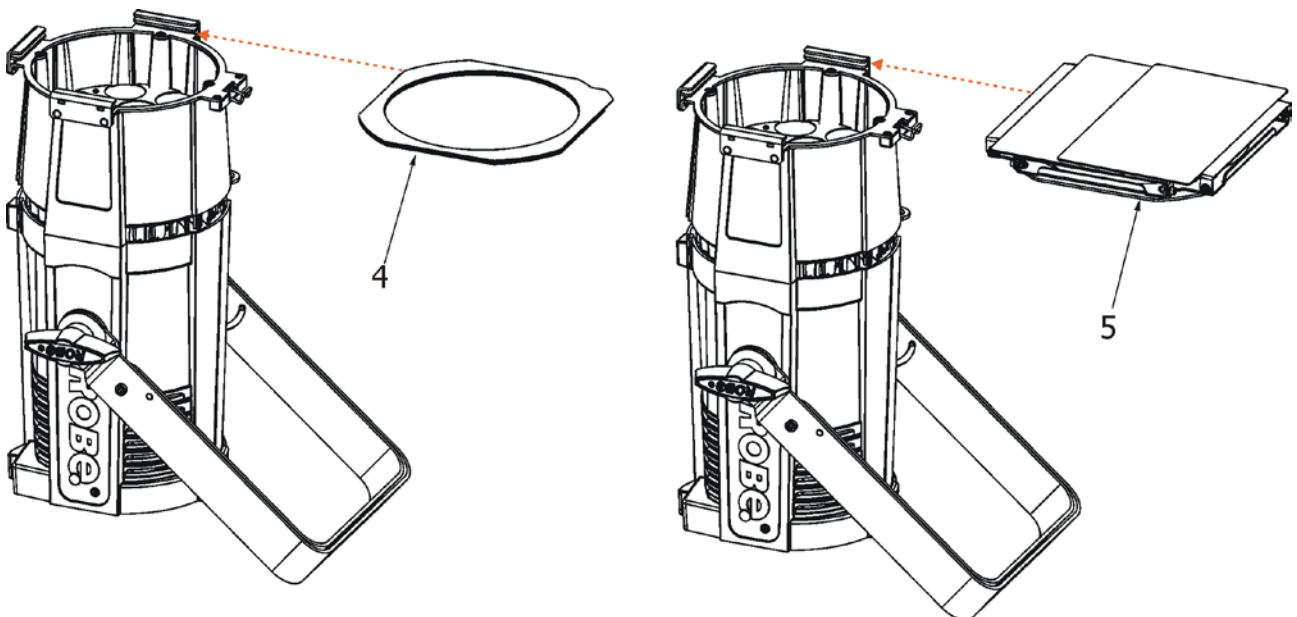

5. Secure both accessories by moving the spring lock (3) up as shows the red arrow on the picture.

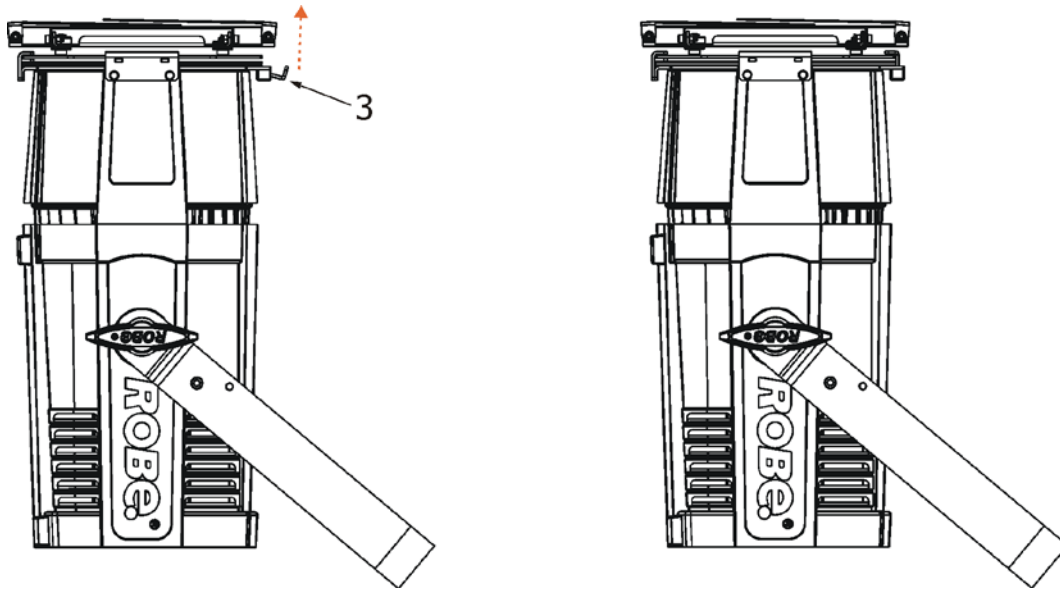

Note: the barndoors can be rotated to desired position and secured in this position via the securing screw (6).

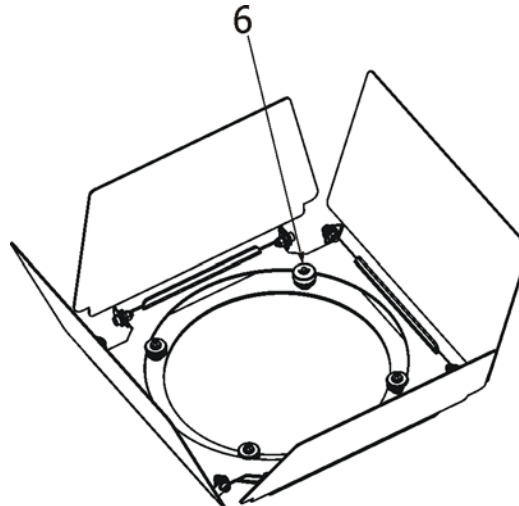

3.4 Rigging the fixture

A structure intended for installation of the fixture (s) must safely hold weight of the fixture(s) placed on it. The structure has to be certificated to the purpose.

The fixture (fixtures) must be installed in accordance with national and local electrical and construction codes and regulation.

For overhead installation, the fixture must be always secured with a safety wire

When rigging, derigging or servicing the fixture staying in the area below the installation place, on bridges, under high working places and other endangered areas is forbidden.

The operator has to make sure that safety-relating and machine-technical installations are approved by an expert before taking into operation for the first time and after changes before taking into operation another time.

The operator has to make sure that safety-relating and machine-technical installations are approved by a skilled person once a year.

Allow the fixture to cool for ten minutes before handling.

The projector should be installed outside areas where persons may walk by or be seated.

IMPORTANT! OVERHEAD RIGGING REQUIRES EXTENSIVE EXPERIENCE, including calculating working load limits, installation material being used, and periodic safety inspection of all installation material and the projector. If you lack these qualifications, do not attempt the installation yourself, but use a help of professional companies.

CAUTION: Fixtures may cause severe injuries when crashing down! If you have doubts concerning the safety of a possible installation, do not install the fixture!

The fixture has to be installed out of the reach of public.

The fixture must never be fixed swinging freely in the room.

When installing the device, make sure there is no highly inflammable material (decoration articles, etc.) in a distance of min. 0.4 m.

CAUTION!
Use an appropriate clamp to rig the fixture on the truss.
Make sure that the device is fixed properly! Ensure that the structure (truss) to which you are attaching the fixtures is secure.

The fixture can be placed by means of the unfolded mounting yoke on the stage floor or rigged on a truss (with folded mounting yoke) without altering its operation characteristics.

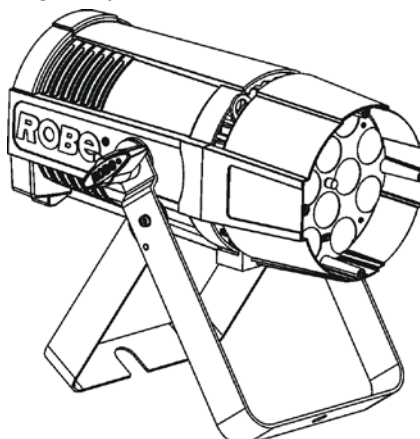

For overhead installation, install a safety wire that can hold at least 10 times the weight of the fixture. Use only safety wire with screw-on carabine. **Fasten the safety cable in the attachment point and around the truss as shown on the picture below.**

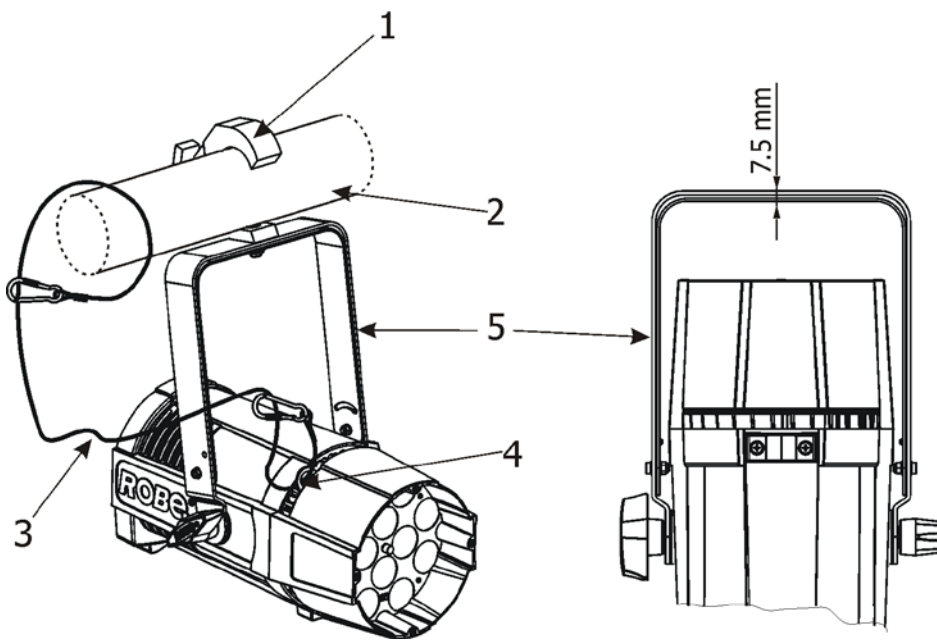

- 1-Clamp
- 2-Truss
- 3-Safety wire
- 4-Attachment point
- 5-Folded mounting yoke

When installing fixtures side-by-side, avoid illuminating one fixture with another!

3.5 DMX-512 connection

The fixture is equipped with 5-pin XLR sockets for DMX input and output. Only use a shielded twisted-pair cable designed for RS-485 and 5-pin XLR-plugs and connectors in order to connect the controller with the fixture or one fixture with another.

DMX - output

XLR mounting-sockets (rear view):

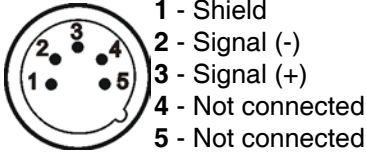

DMX-input

XLR mounting-plugs (rear view):

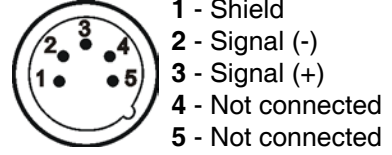

If you are using the standard DMX controllers, you can connect the DMX output of the controller directly with the DMX input of the first fixture in the DMX-chain. If you wish to connect DMX-controllers with other XLR-outputs, you need to use adapter-cables.

Building a serial DMX-chain:

Connect the DMX-output of the first fixture in the DMX-chain with the DMX-input of the next fixture. Always connect one output with the input of the next fixture until all fixtures are connected. Up to 32 fixtures can be interconnected.

Caution: At the last fixture, the DMX-cable has to be terminated with a terminator. Solder a 120 Ω resistor between Signal (-) and Signal (+) into a 5-pin XLR-plug and plug it in the DMX-output of the last fixture.

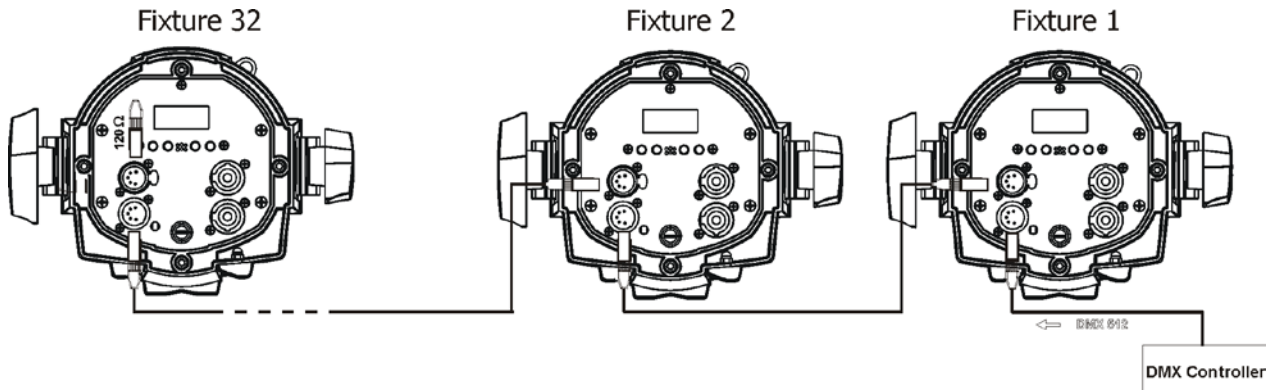

3.6. Wireless DMX operation

The external Robe Wireless CRMX-LB100 module allows receiving wireless DMX. This device is equipped with the Lumen Radio CRMX module and antenna for receiving DMX signal. CRMX module operates on the 2.4 GHz band.

Robe Wireless CRMX-LB100

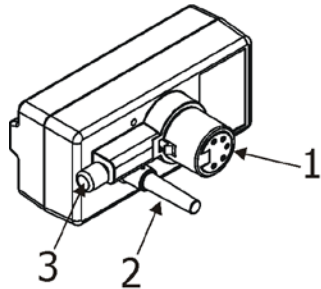

- 1 - 5-pin XLR (female)
- 2 - Locating pin
- 3 - Lock

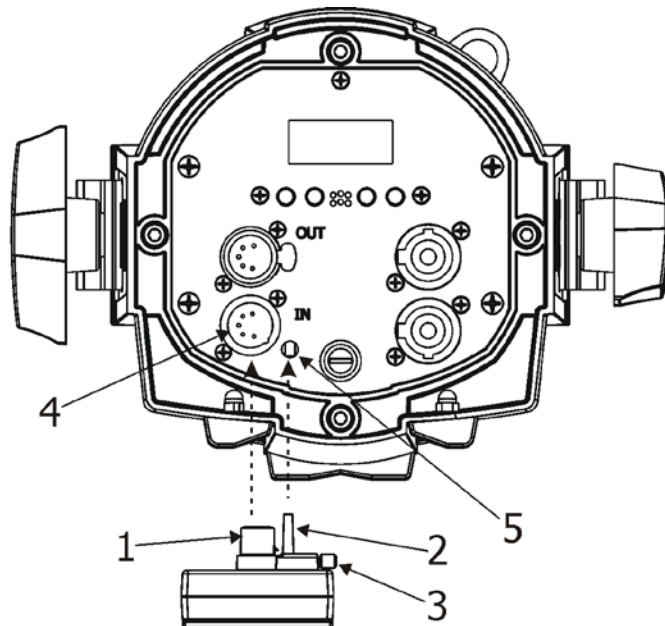

Push in the 5-pin XLR plug (1) into 5-pin XLR socket (4) and simultaneously locating pin (2) into hole (5) in the fixture. In this way the wireless DMX module is connected with the fixture.

NOTE: when you disconnecting the DMX wireless module from the fixture, press and hold lock (5) during getting the wireless module out.

To link the fixture with DMX transmitter.

The fixture can be only linked with the transmitter by running the link procedure at DMX transmitter .

After linking , the level of DMX signal (0-100 %) is displayed in the menu item "Stat" (Special -->Vireless -->Stat).

To unlink the fixture from DMX transmitter.

The fixture can be unlinked from receiver via the menu item " Unlink" (Special-->Vireless -->Unlink.).

3.7. Stand-alone and Master/Slave operation

The fixtures on a data link are not connected to the controller but can execute pre-set programs which can be different for every fixture. To set the program to be played, see the "**Mast/Sla**" menu (DMXA ---> Mast/Sla). The Stand-alone operation can be applied to the single fixture or to multiple fixtures operating synchronously. Synchronous operation of multiple fixtures requires that they must be connected on a data link and one of them is set as a master (master mode) and the rest as the slaves (slave mode). To set the fixture as the master or the slave, see the "**Mast/Sla**" menu.

The master fixture starts simultaneous program start in the other slave fixtures. All fixtures have a definite, synchronized starting point when playing back their programs. Every slave runs its program according to the program number of the master. E.g. if the master runs program number 3, all slaves run their programs number 3.

Note: if the option "Play Master" is selected at the fixture, this slave will play master's program number 3, instead of its own program 3.

Every fixture runs its program repeatedly, starting the program step No.1 when requested by the master.

If the slave fixture has a shorter program length, it will continuously repeat its program until the master fixture finishes its own program and restarts its program running (slave 1- prog. step 3 will not be finished) -see the picture below.

If the slave fixture has a longer program length, it will restart at prog. step 1 before it completes all its prog. steps (slave 2 - prog. step 5 will not be played) - see the picture below.

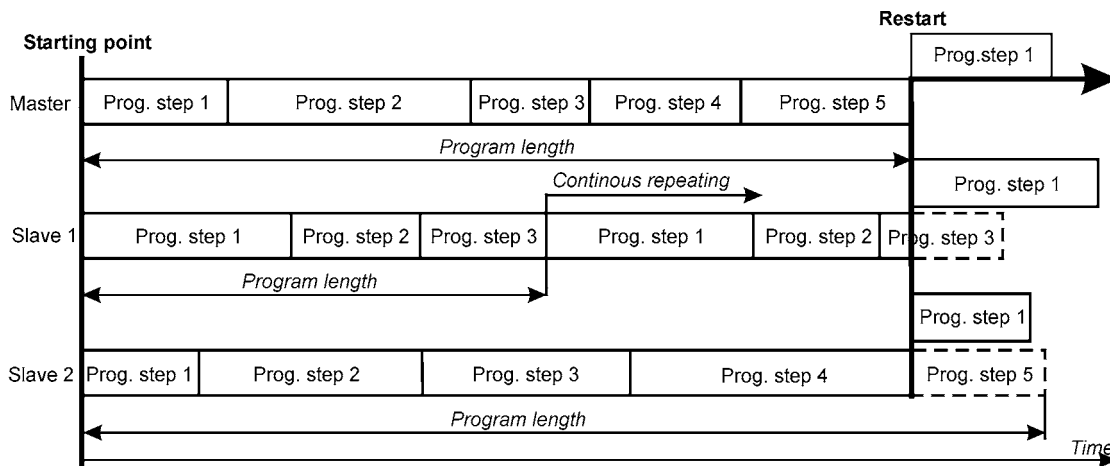

Note: Disconnect the fixtures from the DMX controller before master/slave operating, otherwise data collisions can occur and fixtures will not work properly!

4. Control menu map

Default settings=**Bold print**

Level 1	Level 2	Level 3	Level 4	Level 5	Level 6	Level 7
DMXA	Set DMXA	001-255				
	DMX Pres	Mode 1				
		:				
		Mode 5				
	Mast/Sla	Off				
		Master	Play Prog 1			
			:			
			Play Prog All			
		Slave	Play Master			
			Play Slave			
Info	POn Time	Total				
		Reset				
	DMX In	Powr	0-255			
		:				
		Dim F	0-255			
	Temp	Current				
		Highest				
		High Res				
	Sw Ver	IC-1				
		IC-2				
Pers						
	DMX Pres	Mode 1				
		:				
		Mode 5				
	Display	Turn				
		On/Off T	On, Off			
		Contrast	0-100%			
		Backlight	0-100%			
	C Cal M	On, Off				
	C Mix M	RGBW, CMY				
	Mic Sens	0... 10 ...19				
	Fans	Auto, High				
	Temp Uni	°C, °F				
	I Ef Pos	Pan				
		:				
		Dimm F				
		Store				
	Defaults					
Manual	Pres Eff	R L 1	Pos 1-Pos 5			
		:				
		Dimm	Pos 1- Pos 5			
	Manual C	Powr	0-255			
		:				
		Dim F	0-255			
Test Prg						
Sta Alone	Music T	On, Off				
	Auto Run	Off				

Level 1	Level 2	Level 3	Level 4	Level 5	Level 6	Level 7
		Prog 1				
		:				
		All				
	Pr Play	Prog 1				
		All				
	Pr Edit	Prog 1	Step 1	Powr		
		Prog 2	:	:		
		Prog 3	Step 40	F.Tim	0-25.5	
				S.Tim	0-25.5	
				COPY		
				Prg En	1-40	
Special	RDM Low					
	RDM Hight					
	Wireless	Stat				
		Unlink				
	Adjust	DMX Val	Powr	0-255		
			:			
			Dim F	0-255		
		Calib	Cal Col	Red C	0-255	
				Grn C	0-255	
				Blu C	0-255	
				Whi C	0-255	
				Store		
			Cal Load	Yes,		
				No		
	Sw Upd	On, Off				

5. Robin ParFect 100 - DMX chart

Version 1.2 **Mode 1 - Standard 16 bit, Mode 2 - Reduced 8bit, Mode 3 - Basic,
Mode 4 - Extended 16bit, Mode 5 - Robin 100 LedBeam compatible**

Mode/Channel					Value	Function	Type of control
1	2	3	4	5			
-	-	-	-	1		No function	
-	-	-	-	2		No function	
-	-	-	-	3		No function	
-	-	-	-	4		No function	
-	-	-	-	5		No function	
1	1	1	1	6	0 - 29	Special functions Reserved <i>To activate following functions (30-129DMX), stop in DMX value for at least 3sec. and shutter must be closed at least 3sec. (Shutter channel 12/8/3/28/33 must be at range of 0-31DMX). Corresponding menu items are temporarily over-rided.</i>	step
					30 - 39	RGBW colour mixing mode	step
					40 - 49	CMY colour mixing mode	step
					50-109	Reserved	
					110-114	Colour calibration mode On	step
					115-119	Colour calibration mode Off	step
					120-124	Audio control On	step
					125-129	Audio control Off	step
					130-145	Effect speed control, slow--> fast	proportional
					146-161	Effect speed control, fast--> slow /opposite direction/	proportional
162-255	Reserved						
2	2	-	-	-	0-255	Red/Cyan (8 bit) - all zones Red LEDs saturation control (0-100%)	proportional
3	-	-	-	-	0-255	Red/Cyan fine(16 bit) - all zones Fine red LEDs saturation control	proportional
4	3	-	-	-	0-255	Green/Magenta (8 bit) - all zones Green LEDs saturation control (0-100%)	proportional
5	-	-	-	-	0-255	Green/Magenta fine (16 bit) - all zones Fine green LEDs saturation control	proportional
6	4	-	-	-	0-255	Blue/Yellow (8 bit) - all zones Blue LEDs saturation control (0-100%)	proportional
7	-	-	-	-	0-255	Blue/Yellow fine (16 bit) - all zones Fine blue LEDs saturation control	proportional
8	5	-	-	-	0-255	White (8 bit) - all zones <i>If RGBW mode is selected:</i> White colour saturation control coarse (0-100%) <i>If CMY mode is selected:</i> No function	proportional
9	-	-	-	-	0-255	White fine (16 bit) - all zones Fine white LEDs saturation control (RGBW mode)	proportional
-	-	-	2	7	0-255	Red/Cyan (8 bit) - zone 1 Red LEDs saturation control (0-100%)	proportional
-	-	-	3	8	0-255	Red/Cyan fine (16 bit) - zone 1 Fine red LEDs saturation control	proportional
-	-	-	4	9	0-255	Green/Magenta (8 bit) - zone 1 Green LEDs saturation control (0-100%)	proportional
-	-	-	5	10	0-255	Green/Magenta fine (16 bit) - zone 1 Fine green LEDs saturation control	proportional

Mode/Channel					Value	Function	Type of control
1	2	3	4	5			
-	-	-	6	11	0-255	Blue/Yellow (8 bit) zone 1 Blue LEDs saturation control (0-100%)	proportional
-	-	-	7	12	0-255	Blue/Yellow (16 bit) zone 1 Fine blue LEDs saturation control)	proportional
-	-	-	8	13	0-255	White (8 bit) - zone 1 <i>If RGBW mode is selected:</i> White colour saturation control coarse (0-100%) <i>If CMY mode is selected:</i> No function	proportional
-	-	-	9	14	0-255	White (16 bit) - zone 1 Fine white LEDs saturation control (RGBW mode)	proportional
-	-	-	10	15	0-255	Red/Cyan (8bit) - zone 2 Red LEDs saturation control (0-100%)	proportional
-	-	-	11	16	0-255	Red/Cyan fine (16 bit) - zone 2 Fine red LEDs saturation control	proportional
-	-	-	12	17	0-255	Green/Magenta (8 bit) - zone 2 Green LEDs saturation control (0-100%)	proportional
-	-	-	13	18	0-255	Green/Magenta fine (16 bit) - zone 2 Fine green LEDs saturation control	proportional
-	-	-	14	19	0-255	Blue/Yellow (8 bit) - zone 2 Blue LEDs saturation control (0-100%)	proportional
-	-	-	15	20	0-255	Blue/Yellow fine (16 bit) - zone 2 Fine blue LEDs saturation control	proportional
-	-	-	16	21	0-255	White (8 bit) - zone 2 <i>If RGBW mode is selected:</i> White colour saturation control coarse (0-100%) <i>If CMY mode is selected:</i> No function	proportional
-	-	-	17	22	0-255	White (16 bit) - zone 2 Fine white LEDs saturation control (RGBW mode)	proportional
-	-	-	18	23	0-255	Red/Cyan (8 bit) - zone 3 Red LEDs saturation control (0-100%)	proportional
-	-	-	19	24	0-255	Red/ Cyan fine (16 bit) - zone 3 Fine red LEDs saturation control	proportional
-	-	-	20	25	0-255	Green/Magenta (8 bit) - zone 3 Green LEDs saturation control (0-100%)	proportional
-	-	-	21	26	0-255	Green/Magenta fine (16 bit) - zone 3 Fine green LEDs saturation control	proportional
-	-	-	22	27	0-255	Blue/Yellow (8 bit) zone 3 Blue LEDs saturation control (0-100%)	proportional
-	-	-	23	28	0-255	Blue/Yellow fine (16 bit) zone 3 Fine blue LEDs saturation control	proportional
-	-	-	24	29	0-255	White (8 bit) zone 3 <i>If RGBW mode is selected:</i> White colour saturation control coarse (0-100%) <i>If CMY mode is selected:</i> No function	proportional
-	-	-	25	30	0-255	White fine (16 bit) zone 3 Fine white LEDs saturation control (RGBW mode)	proportional
10	6	-	26	31	0 1-255	CTC No function Colour temperature correction from 19000K to 2700K	step proportional

Mode/Channel					Value	Function	Type of control
1	2	3	4	5			
11	7	2	27	32		Virtual Colour Wheel For detailed description see " Virtual colour wheel- colour mixing chart	
					0	No function	step
					1-2	White 2700 K	step
					3	White 2700 K (Halogen lamp mode*)	step
					4-5	White 3200 K	step
					6	White 3200 K (Halogen lamp mode*)	step
					7-9	White 4200 K	step
					10-12	White 5600 K	step
					13-15	White 8000 K	step
					16	Blue (Blue=full, Red+Green+White=0)	step
					17-55	Red=0, Green->up,Blue =full, White=0	proportional
					56	Light Blue (Red=0, Green=full, Blue =full, White=0)	step
					57 - 95	Red=0, Green=full, Blue->down, White=0	proportional
					96	Green (Red=0, Green=full, Blue =0, White=0)	step
					97 – 134	Red->up, Green=full, Blue=0, White=0	proportional
					135	Yellow (Red=full, Green=full, Blue=0, White=0)	step
					136 - 174	Red=full, Green->down, Blue=0, White=0	proportional
					175	Red(Red=full, Green=0, Blue=0, White=0)	step
					176 -214	Red=full, Green=0, Blue->up, White=0	proportional
					215	Magenta (Red=full, Green=0, Blue=full, White=0)	step
216 - 246	Red -> down, Green=0, Blue=full, White=0	proportional					
247	Blue (Red=0, Green=0, Blue=full, White=0)	step					
<i>Item Audio control = Off (channel Special Functions). The following effects can be controlled by the channel Special Functions (DMX values of 130-161)</i>							
<i>Item Audio control = On (channel Special Functions). The following effects are controlled by sound</i>							
					248	Rainbow effect (with fade time)	step
					249	Rainbow effect	step
					250	Zone effect 1	step
					251	Zone effect 2	step
					252	Zone effect 3	step
					253	Zone effect 4	step
					254	Zone effect 5	step
					255	Random colour selection	step
12	8	3	28	33		Shutter/Strobe	
					0-31	Shutter closed	step
					32-63	Strobe effect from slow--> fast (zones 2,3 only)	proportional
					64-95	Strobe effect from slow--> fast (All zones together)	proportional
					96-127	Reserved	
					128-143	Opening pulses in sequences from slow--> fast (All zones together)	proportional
					144-159	Closing pulses in sequences from fast--> slow (All zones together)	proportional
					160-175	Random strobe effect from slow--> fast (random zone)	proportional
					176-191	Random strobe effect from slow--> fast (random zone + random strobe)	proportional
					192-223	Random strobe effect from slow --> fast (All zones together)	proportional
224-255	Shutter open	step					
13	9	4	29	34		Dimmer (8 bit) Dimmer intensity from 0% to 100%	proportional
14	-	-	30	35		Dimmer fine (16 bit) Fine dimming	proportional

*In the Halogen lamp mode the Dimmer channel imitates behaviour of the halogen lamp during dimming.

5.1 Virtual colour wheel - colour mixing chart

Scale*	Virtual Colour Wheel	Red	Green	Blue	White
	DMX	DMX	DMX	DMX	DMX
1-15	1-2 (White 2700K)	250	118	0	63
	3 (White 2700K /Hal.mode/)	250	118	0	63
	4-5 (White 3200K)	255	141	5	89
	6 (White 3200K /Hal.mode/)	255	141	5	89
	7-9 (White 4200K)	254	141	3	255
	10-12 (White 5600K)	254	207	37	255
	13-15 (White 8000K)	228	255	79	255
16-63	16	0	0	255	0
	17	0	3	255	0
	18	0	6	255	0
	19	0	9	255	0
	20	0	12	255	0
	21	0	15	255	0
	22	0	18	255	0
	23	0	21	255	0
	24	0	24	255	0
	25	0	27	255	0
	26	0	30	255	0
	27	0	36	255	0
	28	0	41	255	0
	29	0	46	255	0
	30	0	52	255	0
	31	0	58	255	0
	32	0	64	255	0
	33	0	68	255	0
	34	0	74	255	0
	35	0	80	255	0
	36	0	86	255	0
	37	0	92	255	0
	38	0	98	255	0
	39	0	104	255	0
	40	0	110	255	0
	41	0	119	255	0
	42	0	129	255	0
	43	0	138	255	0
	44	0	147	255	0
	45	0	156	255	0
	46	0	165	255	0
	47	0	174	255	0
	48	0	183	255	0
	49	0	192	255	0
	50	0	201	255	0
	51	0	210	255	0
	52	0	219	255	0
	53	0	228	255	0
	54	0	237	255	0
	55	0	246	255	0
	56	0	255	255	0
	57	0	255	246	0
	58	0	255	237	0
	59	0	255	228	0
	60	0	255	219	0
	61	0	255	210	0
	62	0	255	201	0
	63	0	255	192	0

Scale*	Virtual Colour Wheel	Red	Green	Blue	White
	DMX	DMX	DMX	DMX	DMX
	64	0	255	183	0
	65	0	255	174	0
	66	0	255	165	0
	67	0	255	156	0
	68	0	255	147	0
	69	0	255	138	0
	70	0	255	129	0
	71	0	255	119	0
	72	0	255	110	0
	73	0	255	104	0
	74	0	255	98	0
	75	0	255	92	0
	76	0	255	86	0
	77	0	255	80	0
	78	0	255	74	0
	79	0	255	68	0
	80	0	255	64	0
	81	0	255	58	0
	82	0	255	52	0
	83	0	255	46	0
	84	0	255	41	0
	82	0	255	36	0
	86	0	255	30	0
	87	0	255	27	0
	88	0	255	24	0
	89	0	255	21	0
	90	0	255	18	0
	91	0	255	15	0
	92	0	255	12	0
	93	0	255	9	0
	94	0	255	6	0
	95	0	255	3	0
	96	0	255	0	0
	97	3	255	0	0
	98	6	255	0	0
	99	9	255	0	0
	100	12	255	0	0
	101	15	255	0	0
	102	18	255	0	0
	103	21	255	0	0
	104	24	255	0	0
	105	27	255	0	0
	106	30	255	0	0
	107	36	255	0	0
	108	41	255	0	0
	109	46	255	0	0
	110	52	255	0	0
	111	58	255	0	0
	112	64	255	0	0
	113	68	255	0	0
	114	74	255	0	0
	115	80	255	0	0
	116	86	255	0	0
	117	92	255	0	0
	118	98	255	0	0

Scale*	Virtual Colour Wheel	Red	Green	Blue	White
	DMX	DMX	DMX	DMX	DMX
	119	104	255	0	0
	120	110	255	0	0
	121	119	255	0	0
	122	129	255	0	0
	123	138	255	0	0
	124	147	255	0	0
	125	156	255	0	0
	126	165	255	0	0
	127	174	255	0	0
	128	183	255	0	0
	129	192	255	0	0
	130	201	255	0	0
	131	210	255	0	0
	132	219	255	0	0
	133	228	255	0	0
	134	240	255	0	0
	135	255	255	0	0
	136	255	246	0	0
	137	255	237	0	0
	138	255	228	0	0
	139	255	219	0	0
	140	255	210	0	0
	141	255	201	0	0
	142	255	192	0	0
	143	255	183	0	0
	144	255	174	0	0
	145	255	165	0	0
	146	255	156	0	0
	147	255	147	0	0
	148	255	138	0	0
	149	255	129	0	0
	150	255	119	0	0
	151	255	110	0	0
	152	255	104	0	0
	153	255	98	0	0
	154	255	92	0	0
	155	255	86	0	0
	156	255	80	0	0
	157	255	74	0	0
	158	255	68	0	0
	159	255	64	0	0
	160	255	58	0	0
	161	255	52	0	0
	162	255	46	0	0
	163	255	41	0	0
	164	255	36	0	0
	165	255	30	0	0
	166	255	27	0	0
	167	255	24	0	0
	168	255	21	0	0
	169	255	18	0	0
	170	255	15	0	0
	171	255	12	0	0
	172	255	9	0	0
	173	255	6	0	0

Scale*	Virtual Colour Wheel	Red	Green	Blue	White
	DMX	DMX	DMX	DMX	DMX
	174	255	3	0	0
	175	255	0	0	0
	176	255	0	3	0
	177	255	0	6	0
	178	255	0	9	0
	179	255	0	12	0
	180	255	0	15	0
	181	255	0	18	0
	182	255	0	21	0
	183	255	0	24	0
	184	255	0	27	0
	185	255	0	30	0
	186	255	0	36	0
	187	255	0	41	0
	188	255	0	46	0
	189	255	0	52	0
	190	255	0	58	0
	191	255	0	64	0
	192	255	0	68	0
	193	255	0	74	0
	194	255	0	80	0
	195	255	0	86	0
	196	255	0	92	0
	197	255	0	98	0
	198	255	0	104	0
	199	255	0	110	0
	200	255	0	119	0
	201	255	0	129	0
	202	255	0	138	0
	203	255	0	147	0
	204	255	0	156	0
	205	255	0	165	0
	206	255	0	174	0
	207	255	0	183	0
	208	255	0	192	0
	209	255	0	201	0
	210	255	0	210	0
	211	255	0	219	0
	212	255	0	228	0
	213	255	0	237	0
	214	255	0	246	0
	215	255	0	255	0
	216	246	0	255	0
	217	237	0	255	0
	218	228	0	255	0
	219	219	0	255	0
	220	210	0	255	0
	221	201	0	255	0
	222	192	0	255	0
	223	183	0	255	0
	224	174	0	255	0
	225	165	0	255	0
	226	156	0	255	0
	227	147	0	255	0
	228	138	0	255	0

Scale*	Virtual Colour Wheel	Red	Green	Blue	White
	DMX	DMX	DMX	DMX	DMX
	229	129	0	255	0
	230	119	0	255	0
	231	110	0	255	0
	232	104	0	255	0
	233	98	0	255	0
	234	91	0	255	0
	235	84	0	255	0
	236	77	0	255	0
	237	70	0	255	0
	238	63	0	255	0
	239	56	0	255	0
	240	49	0	255	0
	241	42	0	255	0
	242	35	0	255	0
	243	28	0	255	0
	244	21	0	255	0
	245	14	0	255	0
	246	7	0	255	0
	247	0	0	255	0
	248-255 (Rainbow+ zone effects)	****	****	****	****

* Colour scale as an illustration only

5.2 LED zone order

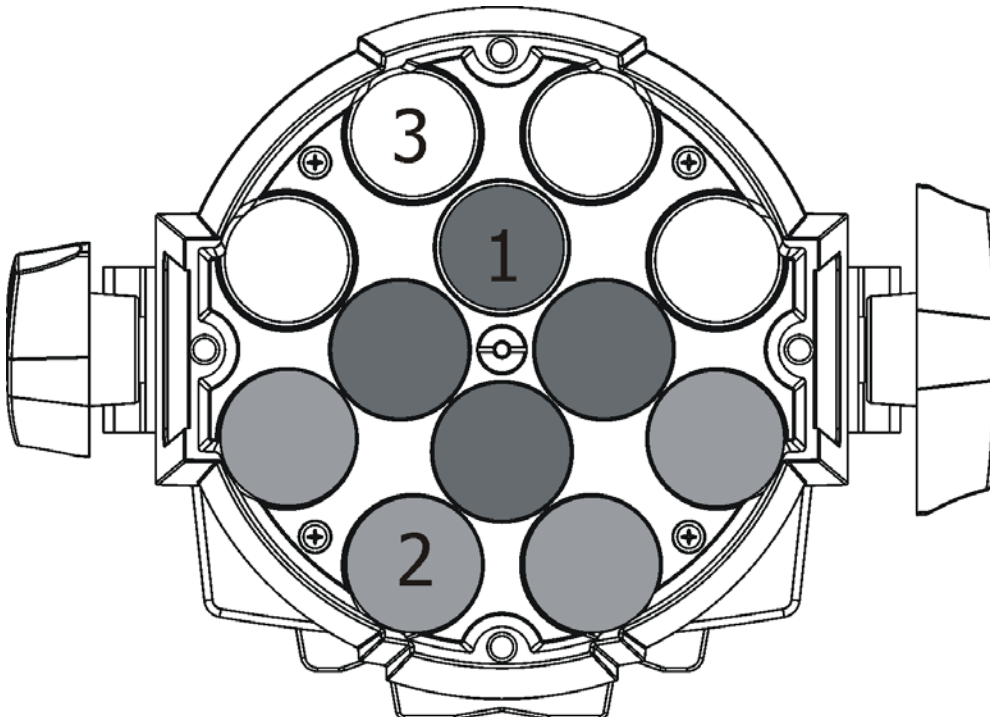

6. Control menu

The ParFect 100 is equipped with 2-row LCD display which allows to set the fixture's behaviour according to your needs, obtain information on its operation, test its various parts and lastly program it, if it has to be used in a stand-alone mode.

Control panel:

[ESCAPE] button used to leave the menu without saving changes.

[NEXT] , [PREV] buttons for moving between menu items and for value adjusting.

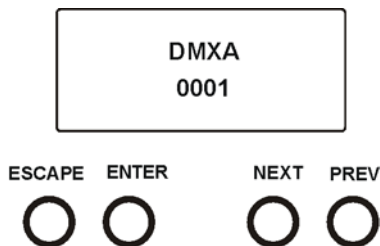

[ENTER] button used to enter the selected menu (menu item) and to confirm adjusted value.

After switching the fixture on, display shows current DMX address.

6.1 Addressing and master/slave setting (DMXA)

Set DMXA- Use this menu item to set the DMX start address of the fixture, which is defined as the first channel from which the ParFect 100 will respond to the controller.

If you set, for example, the address 31, the ParFect 100 will use channels 31 - 44 for control (if Mode 1 is selected).

Please, be sure that you do not have any overlapping channels in order to control each ParFect 100 correctly and independently from any other fixture on the DMX data link.

If there is no data received at the DMX input, the display will start to flash "0001" with actually stored DMX address.

DMX Pres - DMX preset. Use the menu to select desired channel mode.

Mode 1 - 14 control channels (default)

Mode 2 - 9 control channels

Mode 3 - 4 control channels

Mode 4 - 30 control channels

Mode 5 - 35 control channels (compatible to the LEDBeam 100 mode 1)

Mast/Sla- Use this menu item to set the fixture as a master or slave.

Master - The fixture will behave as a master and can play one of ten programs
(**Prog 1-Prog 9, All**)

Master - The fixture will behave as the slave and can play either master's program
(**Play Master**) or its respective program (**Play Slave**).

6.2 Fixture information (Info)

Pon Time - Power on time. Select this menu to read the number of fixture operation hours.

Total - The item shows the total number of the operation hours since the ParFect 100 has been fabricated.

Reset - The item shows the number of the operation hours that the ParFect 100 has been powered on since the counter was last reset.

In order to reset this counter to 0, press and hold both [NEXT] and [PREV] buttons and the [Enter] button at the same time.

DMX In - DMX readout. The menu is used to read DMX values of each channel received by the fixture.

Temp - Temperature. The menu shows temperature in the LED module.

Current - A current temperature of the LED module.

Highest - A maximum temperature of the the LED module since the fixture has been fabricated.

High Res - A maximum temperature of the the LED module since the counter was last reset.

In order to reset this counter, press and hold both [NEXT] and [PREV] buttons and the [Enter] button at the same time.

Sw Ver - Software versions. Select this item to read the software version of the fixture modules.

IC-1 - A display processor.

IC-2 - LED control processor.

6.3 Personality (Pers)

DMX Pres - DMX preset. Use the menu to select desired channel mode.

Mode 1 - 14 control channels (default)

Mode 2 - 9 control channels

Mode 3 - 4 control channels

Mode 4 - 30 control channels

Mode 5 - 35 control channels (compatible to the LEDBeam 100 mode 1)

Display - Display adjusting. This menu allows you to adjust the display behaviour.

Turn - This function turns the display by 180°.

On/Off T - This function allows you to keep the display permanent on or turn it off two minutes after last pressing any button on the control panel.

Contrast - Use this function to adjust contrast of the display (0-100%).

Backlight - Use this function to adjust backlight of the display (0-100%).

C Cal M - Colour calibration mode. If the function is on, the white output (2700K-8000K) from the fixture (and also mixed colours) is more uniform. Each colour is dynamically corrected according to the value set in the menu "Calibrate Effects" (Special-> Adjust-> Calib).

C Mix M - Colour mixing mode. This item allows switching into RGBW or CMY mode. In the CMY mode, the white(8bit)/white (16) bit channels are not active.

Audio - Audio mode. If this mode is on, the effects on the Virtual Colour Wheel are controlled via sound and do not respond to the speed control on the channel Special Functions.

Mic Sens - Microfon sensitivity. Enter the menu if you want to adjust the microphone sensitivity (0-min., 19-max.).

Fans - Fan mode. Use the menu to set the fixture fan to max. fan power mode ("**High**") or to auto- control mode ("**Auto**").

Temp Uni - Temperature unit. Use the menu item to change temperature unit from °C to °F.

I Ef Pos - Init effect positions. Use the menu to set all effects to the desired positions at which they will stay after switching the fixture on without DMX signal connected.

Defaults - The menu item allows to set all fixture parameters to the default (factory) values.

6.4 Manual Control (Manual)

Pres Eff - Preset effects. Use the menu to show preset positions of each channel effect.

Manual C - Manual control. Use the menu to control all fixture channels by means of the control panel.

6.5 Test program (Test Prg)

Use this menu to to run a special demo-test sequences without an external controller, which will show you some possibilities of using the ParFect 100.

6.6 Stand-alone (St Alone)

The ParFect 100 offers seven built-in programs (Prog 4-Prog 9 and "All") and three user-editable programs (Prog 1-Prog 3), each up to 40 steps. The item "All" includes programs 4-9 in a chain.

Music T - Music trigger. Select this function to enable the sound control of the running program via the built-in microphone (the option Audio in the menu Personality has to be set on).

Auto Run - Presetting playback. This function allows you to select the program which will be played in the stand-alone mode after switching the fixture on. Selected program will be played continuously in a loop.

Off - The option disables „Auto Run” function.

Prog 1- All - Selected program will start running after switching the fixture on.

Pr Play - Playing program. Select this menu to run a desired program in a loop.

Prog 1- All - Select the program you wish and press [ENTER]. The selected program starts running. By Pressing the [ENTER] again, the program pauses running. The speed of the running program can be changed by means of the [NEXT] and [PREV] buttons (100%-default value).

Note: adjusted program speed is saved into the fixture and will not be changed until another program speed adjusting is performed or default values are loaded.

Prog 9 - random colour selection, automatically activates music trigger, the change of the colour comes with a sound beat after current step time elapsing.

Pr Edit - Editing program. Select this menu to edit or create three editable programs (Prog 1-Prog 3). Each program step has a step time - during which effects last in the current step and a fade time- during which effects move to new positions.

To edit program.

1. Press [NEXT] or [PREV] to select the menu "Pr Edit" and press [ENTER].
2. Press [NEXT] or [PREV] to select the desired program and press [ENTER] button.
3. Press [NEXT] or [PREV] to select the desired program step and press [ENTER] button.
4. Press [NEXT] or [PREV] to select the desired item and press [ENTER] button. Now you can edit by [NEXT] or [PREV] buttons the DMX value (0-255) for selected item:

Prg En. a total number of the program steps (value 1-40). This value you should be set before starting of programming (e.g. if you want to create program with the 10 steps, set Prg En=10).

Powr a power/special function s channel

CTC a colour temperature correction

R L 1 (2/3) red coarse -zone 1 (2,3)

Vir C a virtual colour

G L 1 (2/3) green coarse - zone 1(2,3)

Stro a strobe/shutter

B L 1 (2/3) blue coarse - zone 1(2,3)

Dimm a dimmer coarse

W 1 (2/3) white coarse - zone 1(2,3)

F.Tim a fade time (0-25.5 sec)

S.Tim a step time (0-25.5 sec)

COPY copying the current prog. step to the next prog. step

5. Press [ENTER] button to confirm adjusted value .

6. Press [ESCAPE] button, select next prog. step, press [ENTER] button and repeat steps 4 - 5).

6.7 Special functions (Special)

RDM Low - This menu item shows the first part of the RDM identification code.

RDM High - This menu item shows the second part of the RDM identification code.

Wireless - Wireless DMX information. The menu allows to read some information about Wireless DMX operation

Stat - Wireless status. Use the menu to read wireless DMX status.

Unlink - use this item to unlink fixture from wireless DMX.

Adjust - Adjustment. The menu allows the fine adjustment of effects.

DMX Val- DMX values. Use the menu to set DMX values of fixture´s channels.

Calib - calibration of white colour.

Cal Col - Use this menu to set white colour 5600K.

Calibration of the white 5600K via the control board

1. Disconnect DMX controller from the fixture , open the sShutter and Dimmer and set the Virtual colour wheel channel at DMX=10 (white 5600K). Aim the light beam on the lux meter (e.g. Minolta CL-200A Chroma meter) which is placed cca 5m from the fixture.
2. Set the menu item Colour Calibration Mode to On (Pers-> C Cal M -> On).
3. Enter the menu "Cal Col".
4. Use the [NEXT] or [PREV] button to select desired colour and press the [ENTER] button.
5. Use the [NEXT] or [PREV] button to set desired value of colour.
5. By means of the "Red C, Grn C, Blue C and Whi C" items adjust the 5600K colour temperature as exactly as possible ($\Delta u'v' = 0$).
7. After adjusting 5600K colour temperature, select item Store and press the [ENTER] button to save all adjusted values .

Note: you can also use DMX controller for colour calibration stated above, calibration protocol is the following:

Effect	Mode 1	Mode 2	Mode 3
Red C - red saturation	channel 31	channel 5	channel 36
Grn C- green saturation	channel 32	channel 6	channel 37
Blu C - blue saturation	channel 33	channel 7	channel 38
Whi C - white saturation	channel 34	channel 8	channel 39

Cal Load - Loads default (factory) calibration.

Sw Upd - Software update. The menu item allows you to update software in the fixture via either serial or USB port of PC.

The following are required in order to update software:

- PC running Windows 95/98/2000/XP/7 or Linux
- Update software
- Flash cable RS232/DMX No.13050624 (if you want to use a serial port of PC)
- Robe Universal Interface (if you want to use an USB port of PC)

Note 1: Software update should execute a qualified person. If you lack qualification, do not attempt the update yourself and ask for help your ROBE distributor.

Note 2: DMX address, , programs 1-3 and all items in the menu "Pers" will be set to their default (factory) values after software update.

To update software in the fixture:

I. Installation of the update software.

1. Update Software available from the ROBE web site at WWW.robe.cz.
2. Make a new directory (e.g. Robe_Uploader) on your hard disk and download the software to it.
3. Unpack the program to the directory.

II. Fixture software updating.

1. Determine which of your ports is available on your PC and connect it:
 - with the DMX input of the fixture if you using the flash cable RS232/DMX
 - with the USB input of the Robe Universal Interface if you using the USB cable. Connect DMX output of the Robe Universal Interface with the fixture via a standard DMX cable.Turn both the computer and the fixture on. Make sure the lamp is switched off (only if the fixture has a lamp).

2. Switch the fixture to the updating mode (Special -> "SW Upd "-> On).

Note: If you do not want to continue in software update, you have to switch off and on the fixture to escape from this menu.

We recommend to cancel all running programs on PC before starting the software update.

3. Run the Software Uploader. Select desired COM and then click on the Connect button. (Select COM if the serial port is used or Robe Universal Interface if the USB port is used).

If the connection is OK, click on the "Start Uploading button" to start uploading. It will take several minutes to perform software update.

If the option "Incremental Update" is not checked, all processors will be updated (including processors with the same software version).

If you wish to update only later versions of processors, check the "Incremental Update box".

Avoid interrupting the process. Update status is being displayed in the Info Box window.

When the update is finished, the line with the text "The fixture is successfully updated" will appear in this window and the fixture will reset with the new software.

Note: In the case of an interruption of the upload process (e.g. power cut), the fixture keeps the updating mode and you have to repeat the software update again.

7. RDM

This fixture supports RDM operation. RDM (Remote Device Management) is a bi-directional communications protocol for use in DMX512 control systems, it is the new open standard for DMX512 device configuration and status monitoring.

The RDM protocol allows data packets to be inserted into a DMX512 data stream without adversely affecting existing non-RDM equipment. By using a special „Start Code,“ and by complying with the timing specifications for DMX512, the RDM protocol allows a console or dedicated RDM controller to send commands to and receive messages from specific moving lights.

RDM allows explicit commands to be sent to a device and responses to be received from it.

The list of commands for the ParFect 100 is the following.

Parameter ID	Discovery command	SET command	GET command
DISC_UNIQUE_BRANCH	*		
DISC_MUTE	*		
DISC_UN_MUTE	*		
DEVICE_INFO			*
SUPPORTED_PARAMETERS			*
SOFTWARE_VERSION_LABEL			*
DMX_START_ADDRESS		*	*
IDENTIFY_DEVICE		*	*
DEVICE_MODEL_DESCRIPTION			*
MANUFACTURER_LABEL			*
DEVICE_LABEL		*	*
SENSOR_DEFINITION			*
SENSOR_VALUE			*
DISPLAY_INVERT		*	*
DISPLAY_LEVEL		*	*
DEVICE_RESET		*	
DMX_PERSONALITY		*	*
DMX_PERSONALITY_DESCRIPTION			*
STATUS_MESSAGES			*
STATUS_ID_DESCRIPTION			*
DEVICE_HOURS			*
PARAMETER_DESCRIPTION			*
ROBE_DMX_INPUT		*	*
ROBE_WIRELESS_UNLINK		*	

8. Error and information messages

Short Err

The message informs you that short circuit has occurred on the LED PCB.

9. Technical Specifications

Electrical

Power supply:.....electronic auto-ranging
Input voltage range:..... supply 100-240V, 50-60Hz
Fuse:.....T 3.15A/250V ~
Max. power consumption *.....200W@230V, I=0.87A, power factor=0.97
*Allow for a deviation of +/-10%

Optic

Light source: 12 Osram Ostar RGBW multichips
3 zones with individual colour control of each
Min LED life expectancy: 20.000 hours
RGBW colour mixing +CTO
Beam angle: 7°

Virtual colour wheel

237 colours including whites (2700K, 3200K, 4200K, 5600K and 8000K)
Halogen lamp effect at whites 2700K and 3200K
Rainbow effect with in both directions with variable speed
Zone effects in both directions with variable speed

Strobe

All LED zones together:
 Strobe effect with variable speed (0.3 - 20Hz)
 Random strobe pulse-effect with variable speed
 Opening/closing pulse effect with variable speed
Independent strobe effect with variable speed (0.3 - 20Hz) at zones 2+3
Random strobe and random LED zone effect

Dimmer

Smooth dimmer from 0 - 100 %

Control

2-row LCD display & 4 buttons
Readout fixture usage, receiving DMX values, temperatures, etc
Built-in analyzer for easy fault finding, error messages
Built-in demo sequences
Silent fan cooling,
Stand-alone operation
3 user editable programs, each up to 40 steps
7 built-in programs
Supported protocols: USITT DMX 512, RDM,
Support of RDM (Remote Device Management)
5 DMX modes (14, 9, 4, 30, 35 control channels)

External Wireless DMX/RDM module (option)

Compliance with USITT DMX-512 (1986 & 1990) and 512-A
Full DMX fidelity and frame integrity
Auto sensing of DMX frame rate and frame size
<5ms DMX latency
Operational frequency range of 2402-2480 MHz
Producer: LumenRadio

Connection

DMX data in/out: Locking 5-pin XLR
AC power input: Chassis connector Neutrik PowerCon, A-type, NAC3MPA
AC power output: Chassis connector Neutrik PowerCon, B-type, NAC3MPB
Note: mains cable is optional accessories

Rigging

Mounting horizontally or vertically via mounting yoke (360° tilt range)

Temperatures

Maximum ambient temperature : 40° C

Maximum surface temperature : 80° C (at LEDs heat sink)

Distances

Min. distance from flammable surfaces: 0.4 m

Min. distance to lighted object: 0.8 m

Total heat dissipation

680 BTU/h (calculated)

Weight (net):

4 kg

Dimensions (mm)

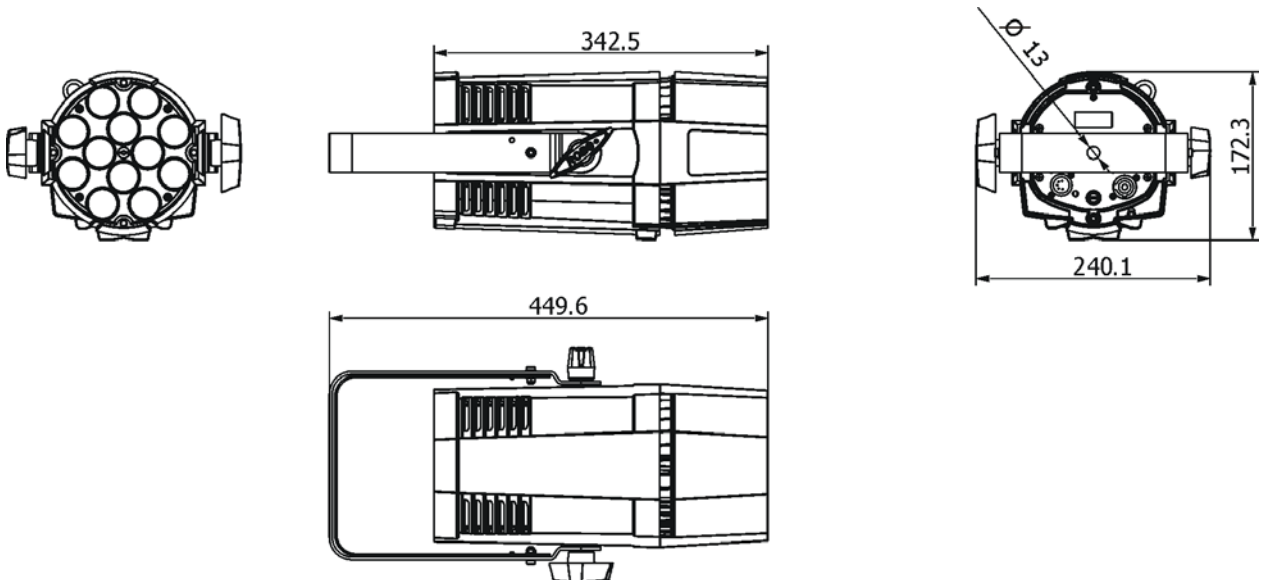

Wireless DMX module: Robe Wireless CRMX-LB100

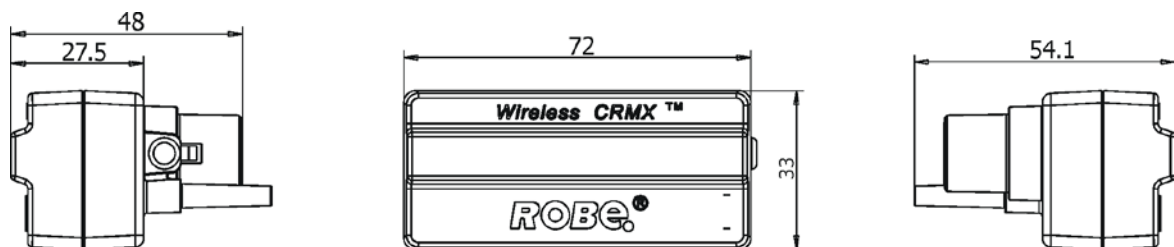

Optional accessories

P/N 10980127) Robe Wireless CRMX-LB100

(P/N 10980187) Diffuser 40° for Perfect 100 black (1 piece)

(P/N 10980185) Diffuser 20° for Perfect 100 black (1 piece)

(P/N 10980191) Diffuser 10° for Perfect 100 black (1 piece)

(P/N 10980188) Diffuser 40° for Perfect 100 black (6 pieces)

(P/N 10980186) Diffuser 20° for Perfect 100 black (6 pieces)

(P/N 10980192) Diffuser 10° for Perfect 100 black (6 pieces)

(P/N 10980215) Diffuser 40° for Perfect 100 white (1 piece)

(P/N 10980213) Diffuser 20° for Perfect 100 white (1 piece)

(P/N 10980217) Diffuser 10° for Perfect 100 white (1 piece)

- (P/N 10980216) Diffuser 40° for Perfect 100 white (6 pieces)
- (P/N 10980214) Diffuser 20° for Perfect 100 white (6 pieces)
- (P/N 10980218) Diffuser 10° for Perfect 100 white (6 pieces)
- (P/N 10980193) Accessory frame adaptor black
- (P/N 10980205) Accessory frame adaptor white
- (P/N 10980189) Barndoor for Perfect 100 black
- (P/N 10980206) Barndoor for Perfect 100 white
- (P/N 10980204) Gel Frame black
- (P/N 10980207) Gel Frame white
- (P/N1305 1731) Mains Cable PowerCon In/open ended, 2m
- (P/N 1305 1724) Mains Cable PowerCon In/Schuko, 2m
- (P/N 1305 1725) Mains Cable PowerCon In/CEE 16A, 2m
- (P/N 1305 1726) Mains Cable PowerCon In/US, 2m
- (P/N 1305 1727) Daisy Chain PowerCon In/Out, EU, 2m
- (P/N 1305 1728) Daisy Chain PowerCon In/Out, US, 2m

10. Maintenance and cleaning

DANGER !
Disconnect from the mains before starting any maintenance work

A soft lint-free cloth moistened with any good glass cleaning fluid is recommended, under no circumstances should alcohol or solvents be used!

Never use alcohol or solvents for cleaning lenses !
Use wet cloth only.

It is absolutely essential that the fixture is kept clean and that dust, dirt and smoke-fluid residues must not build up on or within the fixture. Otherwise, the fixture's light-output will be significantly reduced. Regular cleaning will not only ensure the maximum light-output, but will also allow the fixture to function reliably throughout its life. Lenses may require monthly cleaning as smoke-fluid tends to building up residues, reducing the light-output very quickly. The cooling fan should be cleaned according to the situation (at least annually). The interior of the base should be cleaned at least annually using a vacuum-cleaner or an air-jet. More complicated maintenance and service operations are only to be carried out by authorized distributors. Disassembly of the Perfect 100:

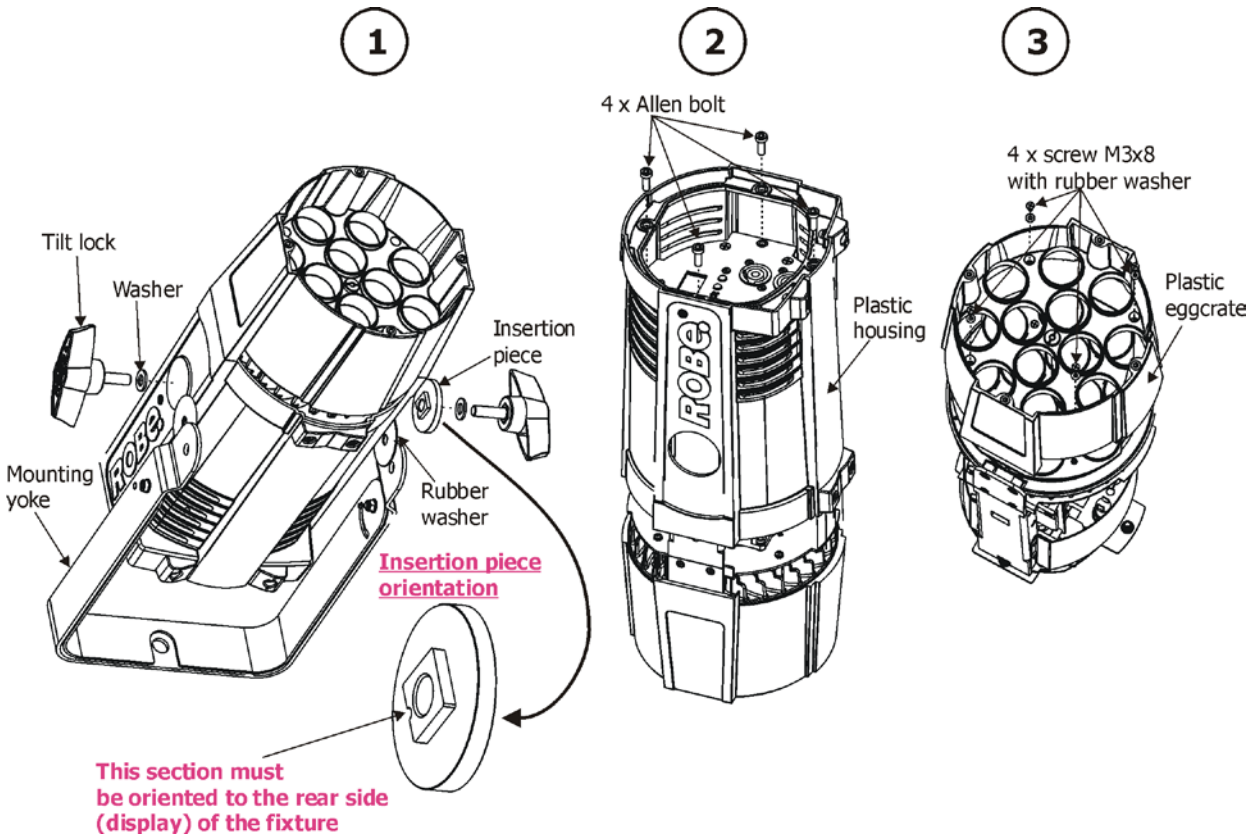

Important: The correct order of parts at the mounting yoke assembly is: insertion piece+rubber washer+yoke+metal washer+tilt lock (on both sides of the device). The correct orientation of the insertion piece must be kept.

10.1 Replacing the fuse

Replace the fuse by a fuse of the same type and rating only.

Before replacing the fuse, unplug mains lead!

- 1) Remove the fuse holder on the rear panel of the base with a fitting screwdriver from the housing (anti-clockwise).
- 2) Remove the old fuse from the fuse holder.
- 3) Install the new fuse in the fuse holder (only the same type and rating).
- 4) Replace the fuseholder in the housing and fix it.

11. Photometric diagrams

Beam angle 7°

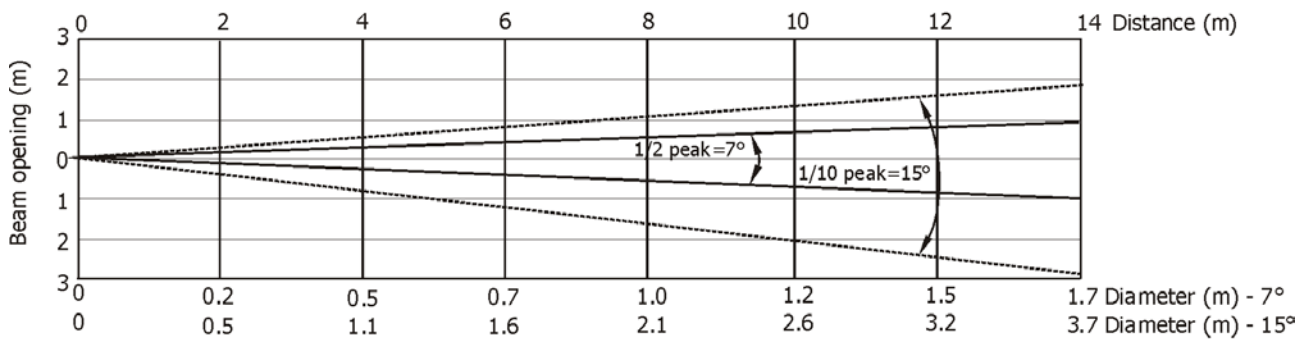

Distance (m)	2	4	5	6	8	10	12	14	
Red	7125/662	1781/166	1140/106	792/74	445/41	285/27	198/18	145/14	Intensity (center) Lux/Footcandles
Green	15188/1411	3797/353	2430/226	1688/157	949/88	608/56	422/39	310/29	
Blue	2000/186	500/47	320/30	222/21	125/12	80/7	56/5	41/4	
White	20125/1870	5031/467	3220/299	2236/208	1258/117	805/75	559/52	411/38	
R+G+B+W	37250/3461	9313/865	5960/554	4139/385	2328/216	1490/138	1035/96	760/71	

Illuminance distribution

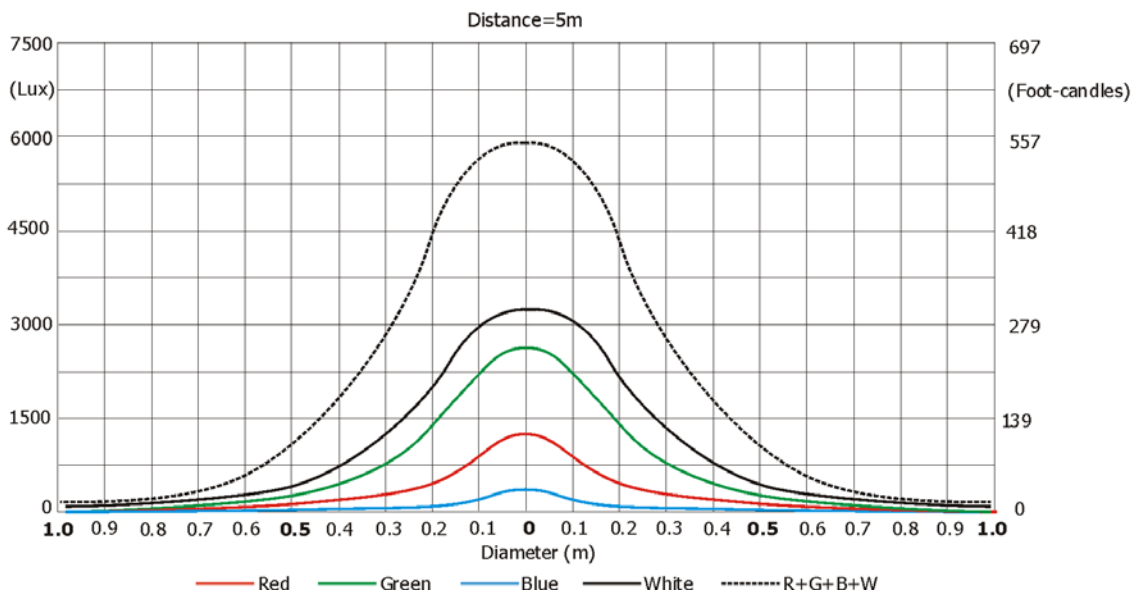

Diffusion filter 10°

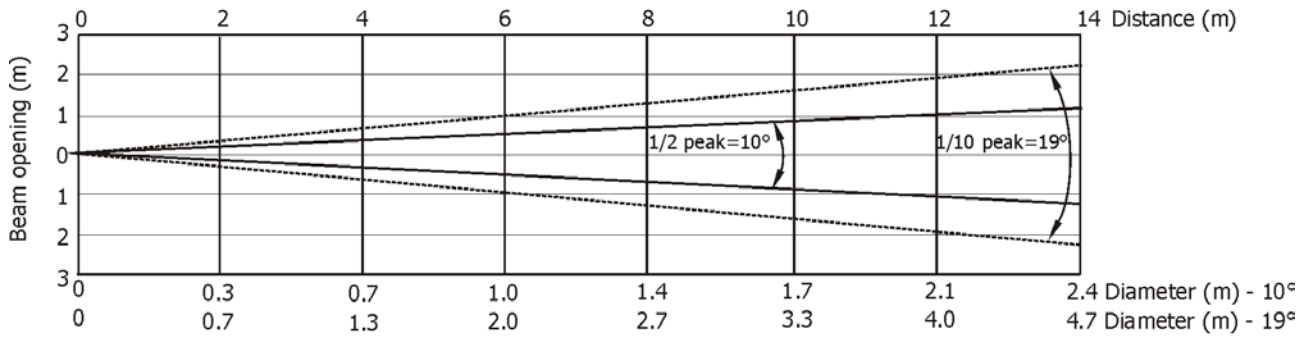

Distance (m)	2	4	5	6	8	10	12	14	
Red	4625/430	1156/107	740/69	514/48	289/26	185/17	128/12	94/9	Intensity (center) Lux/Footcandles
Green	8312/772	2078/193	1330/124	924/86	520/48	333/31	231/22	170/16	
Blue	1069/99	267/25	171/16	118/11	67/6	43/4	30/2.8	22/2	
White	11000/1022	2750/255	1760/164	1222/114	688/64	440/41	305/28	225/21	
R+G+B+W	21625/2009	5406/502	3460/321	2402/223	1351/126	865/80	600/56	441/41	

Illuminance distribution

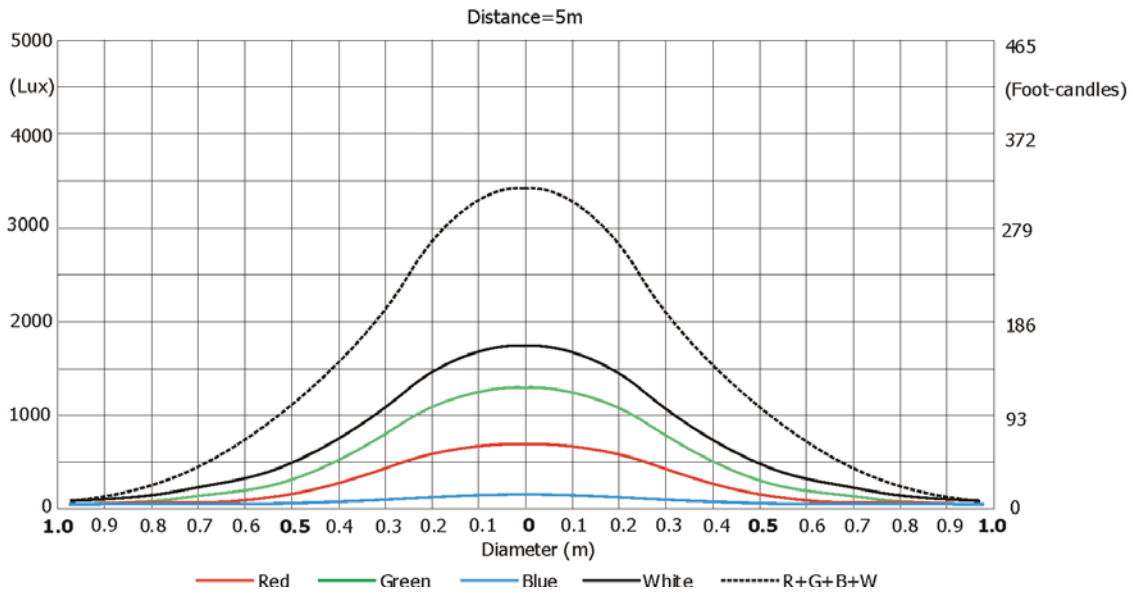

Diffusion filter 20°

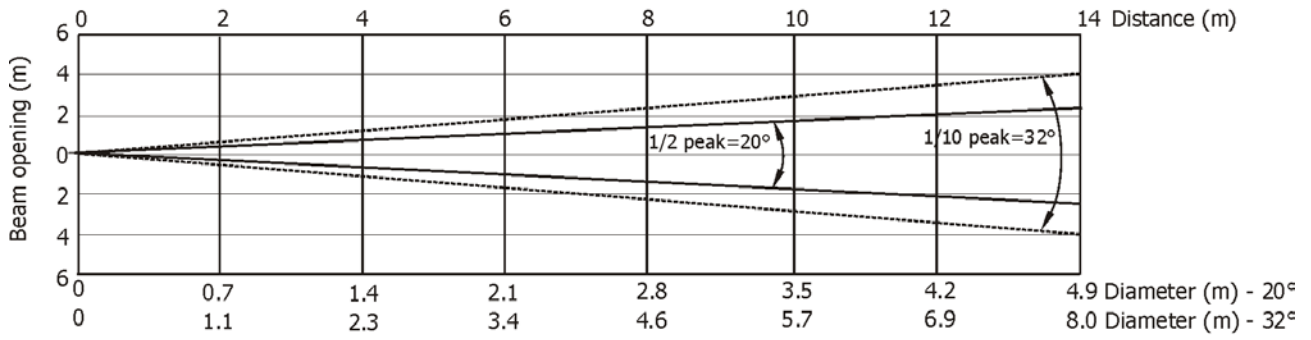

Distance (m)	2	4	5	6	8	10	12	14	
Red	831/77	208/19	133/12	92/9	52/5	33/3	23/2.1	17/1.6	Intensity (center) Lux/Footcandles
Green	2100/195	525/49	336/31	233/22	131/12	84/8	58/5.4	43/4	
Blue	81/7.5	20/1.9	13/1.2	9/0.8	5/0.5	3.3/0.3	2.3/0.2	1.7/0.2	
White	2625/244	656/61	420/39	292/27	164/15	105/9	73/7	54/5	
R+G+B+W	6375/499	1344/125	860/80	597/56	336/32	215/20	149/14	110/10	

Illuminance distribution

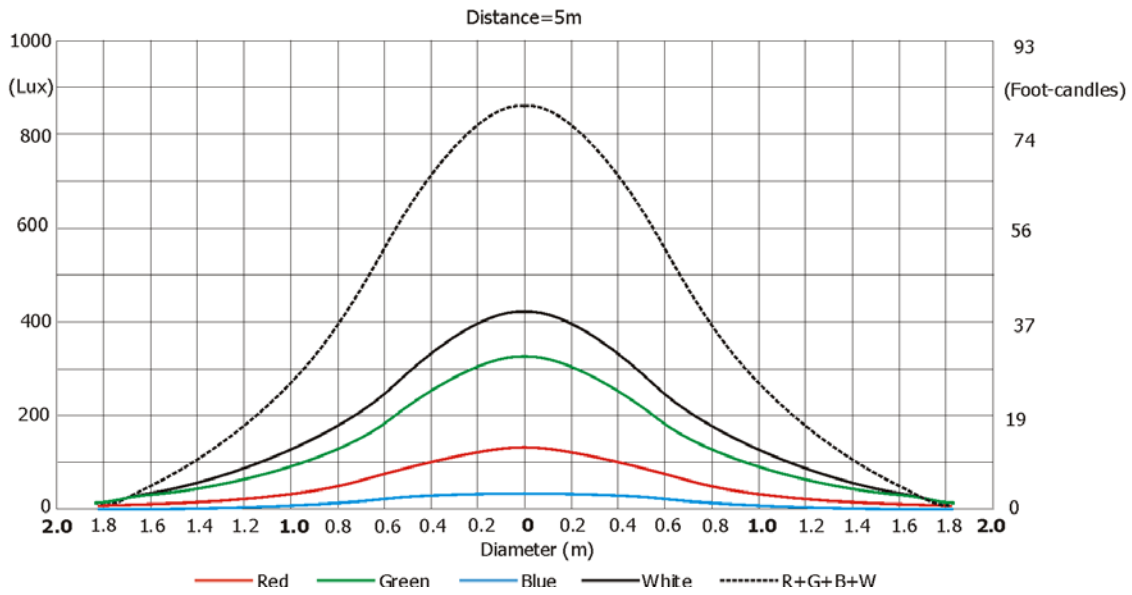

Diffusion filter 40°

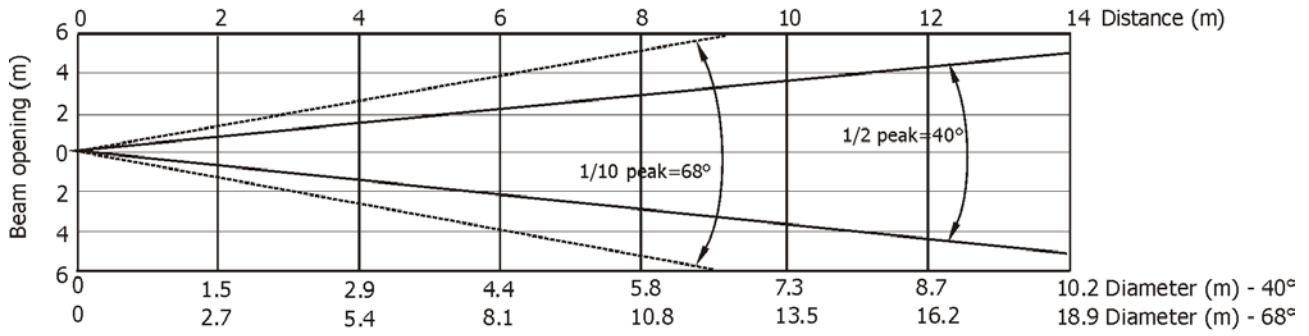

Distance (m)	2	4	5	6	8	10	12	14	
Red	219/20	55/5	35/3.3	24.3/2.3	14/1.3	9/0.8	6/0.6	5/0.4	Intensity (center) Lux/Footcandles
Green	513/48	128/12	82/8	57/5	32/3	21/2	14/1.3	11/1	
Blue	50/4.6	13/1.2	8/0.7	6/0.5	3/0.3	2/0.2	1.4/0.1	1/0.1	
White	725/67	181/17	116/11	81/8	8/45	29/2.7	20/2	15/1.4	
R+G+B+W	1438/133	359/33	230/21	160/15	90/8	58/5	40/4	30/2.7	

Illuminance distribution

